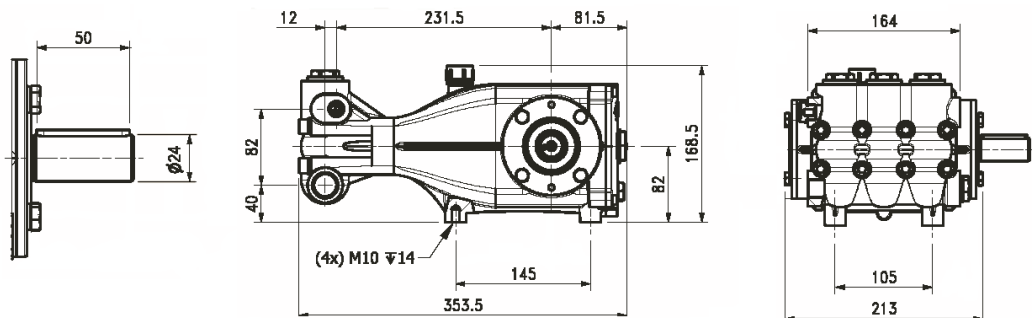

**FEATURES**

- Designed and engineered exclusively for pressure washers.
- Five year limited warranty.
- NEW** • Forged Brass Manifold with FEA computer enhanced design to increase strength in critical areas.
- NEW** • Die Cast Aluminum Crankcase with extended piston rod guides for long seal life.
- NEW** • Die Cast Aluminum Connecting Rods with extended length and size.
- NEW** • Mirror finish Ceramic Plungers with increased thickness to resist thermal shock and corrosion.
- Industrial duty tapered roller bearings.
- Stainless steel inlet and discharge Valve Assemblies.
- Forged valve caps with recessed O-rings to withstand leakage at high pressures.
- Dacromet® coated manifold bolts for extra corrosion resistance.
- U-Seal Packing Assembly for long life and temperature resistance.

**SPECIFICATIONS**

PUMP MODEL	KX 5450
Part Number	8.921-657.0-Right PTO 8.921-658.0-Left PTO
Maximum Volume (GPM)	5.4
Max. Discharge Pressure (PSI)	5000
Maximum Pump Speed	1740
Maximum Inlet Pressure	125 psi
Maximum Inlet Vacuum	9 ft. water (7.9 in. Hg)
Bore	16 mm
Stroke	21 mm
Crankcase Oil Capacity	40.6 oz.
Maximum Fluid Temperature	185° F
Inlet Port Thread	1/2" BSP
Discharge Port Thread	3/8" BSP
Shaft Diameter x Shaft Length	24 mm x 50 mm
Weight	43 lbs
Dimensions (L x W x H)	13.92 x 10.35 x 6.63

**DIMENSIONS**

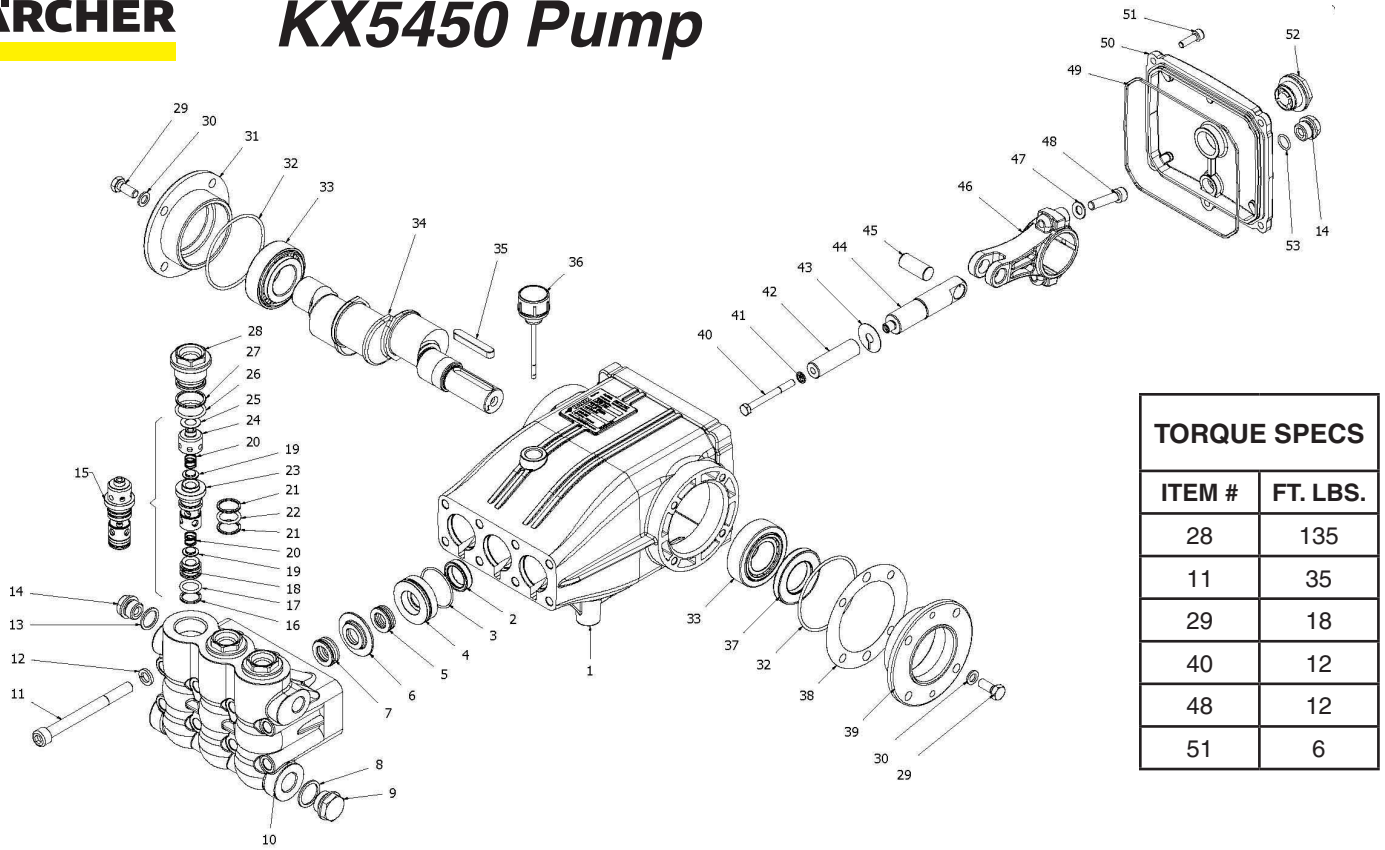

TORQUE SPECS	
ITEM #	FT. LBS.
28	135
11	35
29	18
40	12
48	12
51	6

## PARTS LIST

ITEM	PART NO.	DESCRIPTION	QTY	ITEM	PART NO.	DESCRIPTION	QTY	ITEM	PART NO.	DESCRIPTION	QTY
1	8.752-825.0	Crankcase	1	20*	See Kit Below	Valve Spring	6	39	8.753-509.0	Bearing Housing	3
2*	See Kit Below	Plunger Oil Seal	3	21*	See Kit Below	Back Ring	6	40*	8.752-841.0	Plunger Bolt	3
3*	See Kit Below	O'Ring, 2150 Ø1.78 x 37.82	3	22*	See Kit Below	O'Ring, 3068 Ø2.62 x 17.13	6	41*	8.752-820.0	Bonded Seal	3
4*	See Kit Below	Pressure Ring 16mm	3	23*	See Kit Below	Valve Cage	3	42*	8.753-510.0	Plunger 16mm	3
5*	See Kit Below	U-Seal, 16mm	3	24*	See Kit Below	Valve Cage	3	43*	8.752-823.0	Copper Spacer	6
6*	See Kit Below	Intermediate Ring 16mm	3	25*	See Kit Below	Copper Washer	3	44	8.753-511.0	Plunger Rod	6
7*	See Kit Below	U-Seal, 16mm	3	26	8.753-505.0	O'Ring, 3093 Ø2.62 x 23.47	3	45	8.752-822.0	Connecting Rod Pin	1
8	9.803-199.0	Copper Washer 1/2	1	27	8.753-506.0	Back Ring	3	46	8.752-821.0	Connecting Rod	1
9	9.802-926.0	Brass Plug, G1/2	1	28	8.753-507.0	Valve Plug	3	47	9.802-889.0	Spring Washer	1
10	8.753-502.0	Manifold Housing Ø16	1	29	8.752-830.0	Hexagonal Screw	8	48	9.802-937.0	Screw, Connecting Rod	6
11	8.753-503.0	Manifold Stud Bolt	8	30	9.802-884.0	Washer	8	49	9.803-194.0	O'Ring, Ø2.62 x 152.07	1
12	9.802-890.0	Lock-Washer	8	31	9.803-182.0	Closed Bearing Housing	1	50	8.752-826.0	Crankcase Cover	1
13	8.719-008.0	Copper Washer 3/8	1	32	9.803-186.0	O'Ring, Ø2.62 x 71.12	2	51	8.752-824.0	Cover Screw	5
14	8.707-262.0	Brass Plug, G3/8	2	33	9.803-160.0	Roller Bearing	2	52	9.803-202.0	Sight Glass, G3/4	1
15	8.753-504.0	Valve Assembly	3	34	8.753-508.0	Crankshaft, Ø24	1	53	9.803-906.0	O'Ring, Ø1.78 x 14.00	1
16*	See Kit Below	Back Ring	3	35	9.803-293.0	Crankshaft Key	1				
17*	See Kit Below	O'Ring, 119 Ø2.62 x 15.08	3	36	8.752-834.0	Oil Dipstick	1				
18*	See Kit Below	Valve Seat	3	37	9.803-139.0	Crankshaft Seal	3				
19*	See Kit Below	Valve Plate	6	38	9.803-177.0	Shim, .10mm	3				

\* Available in Kit (See Below)

## REPAIR KITS

KIT NUMBERS	8.753-512.0	8.753-513.0	8.753-514.0	8.753-515.0	8.752-835.0
KIT DESCRIPTION	Plunger Seals 16mm	Seal Packing 16mm	Plunger 16mm	Complete Valve	Plunger Oil Seals
ITEMS NUMBERS INCLUDED	3, 5, 7	3, 4, 5, 6, 7	40, 41, 42, 43	15	2
NUMBER OF CYLINDERS KIT WILL SERVICE	3	1	1	6	3