

FEATURES

- Designed and engineered exclusively for pressure washers.
- Five year limited warranty.
- NEW** • Forged Brass Manifold with FEA computer enhanced design to increase strength in critical areas.
- NEW** • Die Cast Aluminum Crankcase with extended piston rod guides for long seal life.
- NEW** • Die Cast Aluminum Connecting Rods with extended length and size.
- NEW** • Mirror finish Ceramic Plungers with increased thickness to resist thermal shock and corrosion.
- Industrial duty tapered roller bearings.
- Stainless steel inlet and discharge Valve Assemblies.
- Forged valve caps with recessed O-rings to withstand leakage at high pressures.
- Dacromet® coated manifold bolts for extra corrosion resistance.
- U-Seal Packing Assembly for long life and temperature resistance.



SPECIFICATIONS

PUMP MODEL	GT4540.2	GT6036.2	GT5636.2
Part Number	8.921-722.0 - Right PTO 8.921-723.0 - Left PTO	8.921-724.0 - Right PTO 8.921-725.0 - Left PTO	8.921-726.0 - Right PTO 8.921-727.0 - Left PTO
Maximum Volume (GPM)	4.5	6.0	5.6
Max. Discharge Pressure (PSI)	4000	3600	3600
Maximum Pump Speed	1360	1450	
Maximum Inlet Pressure	125 psi		
Maximum Inlet Vacuum	9 ft. water (7.9 in. Hg)		
Bore	18mm		
Stroke	17mm	21mm	20mm
Crankcase Oil Capacity	40.6 oz.		
Maximum Fluid Temperature	185° F		
Inlet Port Thread	1/2" BSP		
Discharge Port Thread	3/8" BSP		
Shaft Diameter x Shaft Length	25mm x 50mm		24mm x 50mm
Weight	39 lbs		
Dimensions (L x W x H)	12.9 x 10.00 x 6.6		

DIMENSIONS

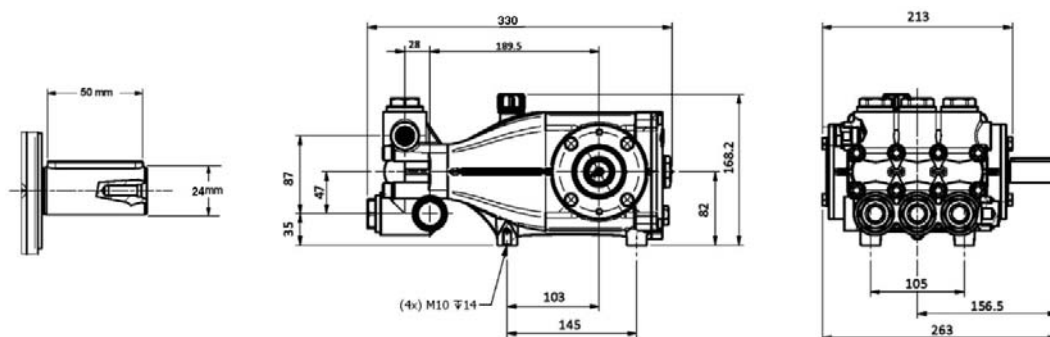

Legacy GT.2 Pump Series

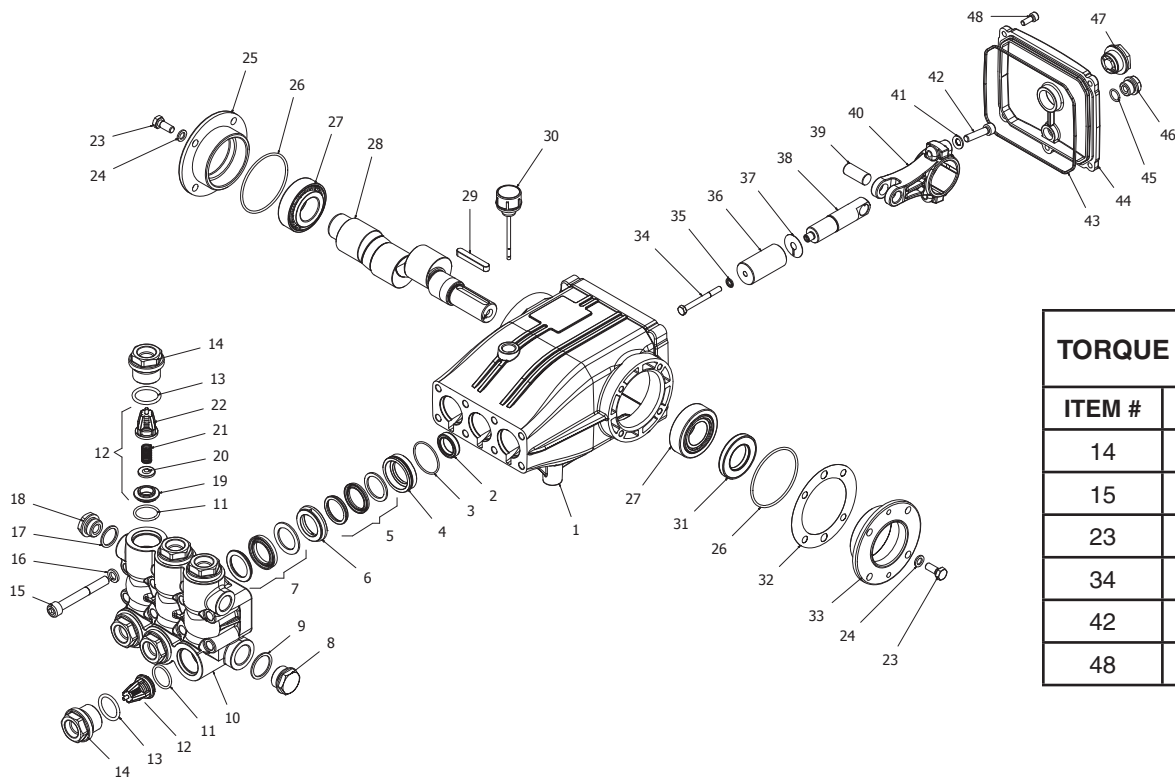

TORQUE SPECS	
ITEM #	FT. LBS.
14	135
15	35
23	18
34	12
42	12
48	6

PARTS LIST

ITEM	PART NO.	DESCRIPTION	QTY	ITEM	PART NO.	DESCRIPTION	QTY	ITEM	PART NO.	DESCRIPTION	QTY
1	8.752-825.0	Crankcase	1	18	8.707-262.0	Brass Plug 3/8	1	33	9.803-181.0	Bearing Housing	1
2*	See Kit Below	Plunger Oil Seal	3	19	See Kit Below	Valve Seat	6	34*	8.752-841.0	Plunger Bolt	3
3*	See Kit Below	O-Ring Ø1.78 x 37.82	3	20	See Kit Below	Valve Plate	6	35*	8.752-820.0	Bonded Seal	3
4*	See Kit Below	Pressure Ring, 18mm	3	21	See Kit Below	Valve Spring	6	36*	8.753-819.0	Plunger, 18mm	3
5*	See Kit Below	U-Seal, 18mm	3	22	See Kit Below	Valve Cage	6	37*	8.752-823.0	Copper Spacer	3
6*	See Kit Below	Intermediate Ring, 18mm	3	23	8.752-830.0	Hex Screw	8	38	8.753-820.0	Plunger Rod	3
7*	See Kit Below	U-Seal, 18mm	3	24	9.802-884.0	Washer	8	39	8.752-822.0	Connecting Rod Pin	3
8	9.802-926.0	Brass Plug, G1/2	1	25	9.803-182.0	Closed Bearing Housing	1	40	8.752-821.0	Connecting Rod	3
9	9.803-199.0	Copper Washer 1/2	1	26	9.803-186.0	O-Ring Ø2.62 x 71.12	2	41	9.802-889.0	Spring Washer	6
10	8.753-816.0	Manifold Housing	1	27	9.803-160.0	Roller Bearing	2	42	9.802-937.0	Connecting Rod Screw	6
11*	9.804-498.0	O-Ring Ø2.62 x 25.1	6	28	8.753-818.0	Crankshaft Ø25 (4540)	1	43	9.803-194.0	O-Ring Ø2.62 x 152.07	1
12*	See Kit Below	Valve Assembly	6		8.752-827.0	Crankshaft Ø25 (6036)	1	44	8.752-826.0	Crankcase Cover	1
13*	9.803-193.0	O-Ring 3068	6		8.753-898.0	Crankshaft Ø24 (5636)	1	45	9.803-906.0	O-Ring Ø1.78 x 14.00	1
14	9.802-928.0	Valve Plug	6	29	9.803-167.0	Crankshaft Key	1	46	8.707-262.0	Brass Plug G3/8	1
15	8.753-817.0	Manifold Stud Bolt	8	30	8.752-834.0	Oil Dip Stick	1	47	9.803-202.0	Sight Glass G3/4	1
16	9.802-890.0	Lock Washer	8	31	9.803-139.0	Crankshaft Seal	1	48	8.752-824.0	Cover Screw	5
17	8.719-008.0	Copper Washer 3/8	1	32	9.803-177.0	Shim	2				

* Available in kit (See below)

REPAIR KITS

KIT NUMBERS	8.753-821.0	8.753-822.0	8.753-823.0	8.753-824.0	8.752-835.0
KIT DESCRIPTION	Plunger Seals 18 mm	Seal Packing 18 mm	Plunger 18 mm	Complete Valve	Plunger Oil Seals
ITEMS NUMBERS INCLUDED	3, 5, 7	3, 4, 5, 6, 7,	34, 35, 36, 37	11, 12, 13	2
NUMBER OF CYLINDERS KIT WILL SERVICE	3	1	1	6	3