

FEATURES

- Designed and engineered for pressure washers.
- Five year limited warranty.
- Forged brass manifold with an exclusive lifetime warranty.
- Large capacity, die-cast, anodized aluminum oil-bath crankcase.
- Over-sized connecting rods and crankshaft for maximum life.
- Heavy-duty tapered roller bearing.
- Solid ceramic plungers with mirror finish and corrosion resistance.
- Long life seals.
- Stainless steel inlet and discharge valve assemblies.
- Forged valve caps with recessed O-rings to withstand high pressures.
- Dacromet® coated manifold bolts for superior corrosion resistance.

**SPECIFICATIONS**

PUMP MODEL	KT-4035.1	KT-4040.1	KT-5030.1	KT-6035.1
Maximum Volume (GPM)	4.2	4	5	6
Max. Discharge Pressure (PSI)	4000	4000	3000	3500
Maximum Pump Speed	1325	1030	1060	1540
Maximum Inlet Pressure	125 psi			
Maximum Inlet Vacuum	9 ft. water (7.9 in. Hg)			
Bore	20	20	22	20
Stroke	14	17	17	17
Crankcase Oil Capacity	40.6 oz.			
Maximum Fluid Temperature	165° F			
Inlet Port Thread	1/2-14 BSPP-F			
Discharge Port Thread	3/8-19 BSPP-F			
Shaft Diameter	25 mm			
Weight	33 lbs.			
Dimensions	12.5 x 9.3 x 6.9 in.			

KT.1 Series Pump with U-Seals

- 8.904-949.0 KT4035.1 Right
- 8.916-546.0 KT4035.1 Left
- 8.916-547.0 KT4040.1 Right
- 8.916-548.0 KT4040.1 Left
- 8.916-549.0 KT5030.1 Right
- 8.916-550.0 KT5030.1 Left
- 8.904-956.0 KT6035.1 Right
- 8.916-551.0 KT6035.1 Left

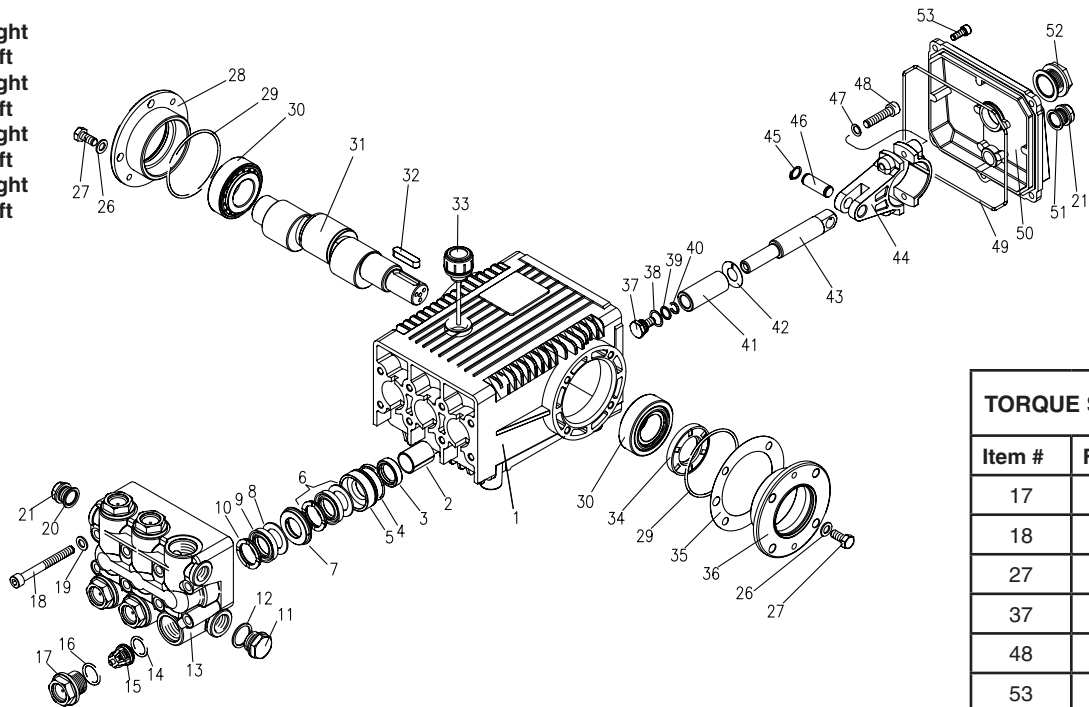

TORQUE SPECS	
Item #	Ft.-Lbs.
17	75
18	45
27	18
37	10
48	30
53	7.6

PARTS LIST

ITEM	PART NO.	DESCRIPTION	QTY	ITEM	PART NO.	DESCRIPTION	QTY	ITEM	PART NO.	DESCRIPTION	QTY
1	9.804-604.0	Crankcase	1	19	9.802-890.0	Washer	8	39*	See Kit Below	O-Ring Ø1.78 x10.82	3
2	9.803-195.0	Plunger Guide	3	20	9.803-198.0	Copper Washer 3/8"	1	40*	See Kit Below	Teflon Ring	3
3*	See Kit Below	Plunger Oil Seal	3	21	9.802-925.0	Brass Plug 3/8"	1	41*	See Kit Below	Plunger	3
4*	See Kit Below	O-Ring Ø1.78 x 31.47	3	26	9.802-884.0	Washer	8	42*	See Kit Below	Copper Spacer	3
5*	See Kit Below	"Pressure Ring, Brass	3	27	9.802-944.0	Hexagonal Screw	8	43	9.803-143.0	Plunger Rod	3
6*	See Kit Below	"U" Seal Low Pressure	3	28	9.803-182.0	Closed Bearing Housing	1	44	9.803-157.0	Connecting Rod	3
7*	See Kit Below	Intermediate Ring, Brass	3	29	9.803-186.0	O-Ring Ø2.62 x 71.12	2	45	9.802-912.0	Snap Ring	6
8*	See Kit Below	Support Ring, Teflon Bronze	3	30	9.803-160.0	Roller Bearing, Tapered	2	46	9.802-915.0	Connecting Rod Pin	3
9*	See Kit Below	"U" Seal High Pressure	3	31	9.803-148.0	Crankshaft (GT4040.1, 5030.1, 6035.1)	1	47	9.802-889.0	Spring Washer	6
10*	See Kit Below	Support Ring	3		9.803-149.0	Crankshaft (GT 4035.1)	1	48	9.802-937.0	Connecting Rod Screw	6
11	9.802-926.0	Brass Plug, 1/2"	1	32	9.803-167.0	Crankshaft Key	1	49	9.803-194.0	O-Ring Ø2.62 x 152.07	1
12	9.803-199.0	Copper Washer 1/2"	1	33	9.802-923.0	Oil Dip Stick	1	50	9.803-166.0	Crankcase Cover	1
13	9.802-933.0	Manifold Head	1	34	9.803-139.0	Crankshaft Seal	1	51	9.803-197.0	Gasket, G3/8	1
14*	See Kit Below	O-Ring Ø2.62 x 17.13	6	35	9.803-177.0	Shim	2	52	9.803-202.0	Sight Glass G3/4	1
15*	See Kit Below	Valve Assembly	6	36	9.803-181.0	Bearing Housing	1	53	9.802-939.0	Cover Screw	5
16	See Kit Below	O-Ring Ø2.62 x 20.29	6	37*	See Kit Below	Plunger Bolt	3				
17	9.802-928.0	Valve Plug	6	38*	See Kit Below	Copper Spacer	3				
18	9.802-943.0	Manifold Stud Bolt	8								

* Part available in kit (See below)

REPAIR KITS

REPAIR KIT NUMBER	8.916-488.0	8.916-487.0	8.916-322.0	8.916-323.0	9.802-607.0	9.802-611.0	9.802-603.0	9.802-606.0
KIT DESCRIPTION	Plunger "U" Seal 20mm 4040.1 6035.1 4035.1	Plunger "U" Seal 22mm 5030.1	"U" Seal Packing Assy 20mm 4040.1 6035.1 4035.1	"U" Seal Packing Assy 22mm 5030.1	Plunger 20mm 4040.1 6035.1 4035.1	Plunger 22mm 5030.1	Complete Valve (all pumps)	Plunger Oil Seals (all pumps)
ITEM NUMBERS INCLUDED	4, 6, 8, 9, 10	4, 6, 8, 9, 10	4, 5, 6, 7, 8, 9, 10,	4, 5, 6, 7, 8, 9, 10,	37, 38, 39, 40, 41, 42	37, 38, 39, 40, 41, 42	14, 15, 16	3
NUMBER OF CYLINDERS KIT WILL SERVICE	3	3	1	1	1	1	6	3