



FEATURES

- Designed and engineered exclusively for pressure washers.
- Seven year limited warranty.
- Forged brass manifold with an exclusive lifetime warranty.
- Large capacity, die-cast, anodized aluminum oil-bath crankcase with cooling fins.
- Over-sized connecting rods for maximum life.
- Heavy-duty tapered roller bearing.
- Solid ceramic plungers with mirror finish and corrosion resistance.
- Stainless steel inlet and discharge valve assemblies.
- Forged valve caps with recessed O-rings to withstand high pressures..
- Dacromet® coated manifold bolts for extra corrosion resistance.
- Long life seals.



SPECIFICATIONS

PUMP MODEL	KM4030.2	KM4035.2	KM5030.2	KM6035.2	KM3540.2
Maximum Volume (GPM)	4	4.8	5.1	5.6	3.5
Max. Discharge Pressure (PSI)	3000	3500	3000	3500	4000
Maximum Pump Speed	1000	1500	1550	1740	1850
Maximum Inlet Pressure	125 PSI				
Maximum Inlet Vacuum	9 ft. water (7.9 in. HG)				
Bore	20 mm	18 mm	20 mm	18 mm	15 mm
Stroke	17mm	17 mm	14.3 mm	17 mm	14.3 mm
Crankcase Oil Capacity	23.3 oz.				
Maximum Fluid Temperature	185° F				
Inlet Port Thread	1/2-14 BSPP-F				
Discharge Port Thread	3/8-19 BSPP-F				
Shaft Diameter	24 mm				
Weight	22 lbs				
Dimensions (LxWxH)	11 x 8.8 x 5.4 in.				

KM.2 Series Pump

- 9.803-405.0 KM4030R.2
- 9.803-406.0 KM4030L.2
- 9.802-343.0 KM4035R.2
- 9.803-407.0 KM4035L.2
- 9.802-342.0 KM5030R.2
- 9.803-408.0 KM5030L.2
- 8.749-940.0 KM6035R.2
- 8.749-940.0 KM6035L.2
- 8.904-689.0 KM3540R.2

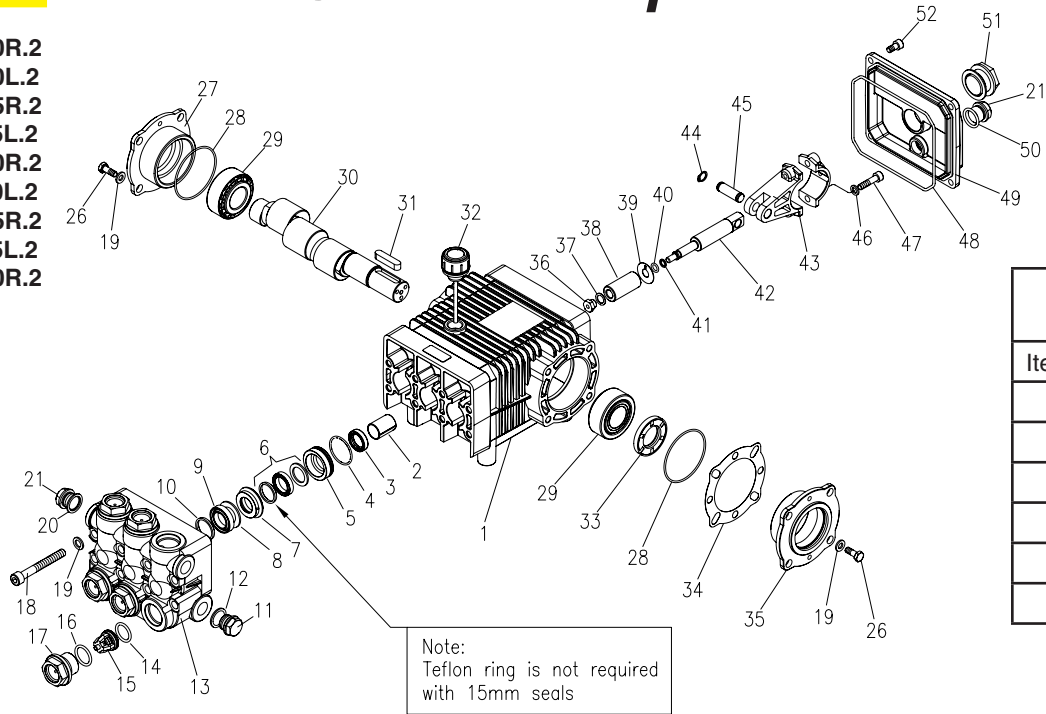

TORQUE SPECS	
Item #	Ft.-lbs
17	75
18	30
26	8
36	9
47	13
52	7.6

PARTS LIST

ITEM	PART NO.	DESCRIPTION	QTY	ITEM	PART NO.	DESCRIPTION	QTY	ITEM	PART NO.	DESCRIPTION	QTY
1	8.717-130.0	Crankcase	1	26	9.802-944.0	Screw, Hex, 8mm x 18mm	8	40*	See Kits Below	Plunger (4035, 6035)	3
2	9.803-196.0	Plunger Guide	3						See Kits Below	Plunger (4030, 5030)	3
3*	See Kits Below	Plunger Oil Seal	3						See Kits Below	Plunger (3540)	3
4*	See Kits Below	O-Ring Ø1.78 x 31.47	3	27	8.717-210.0	Closed Bearing Housing	1	41*	See Kits Below	Copper Spacer	3
5*	See Kits Below	Pressure Ring	3	28	9.803-192.0	O-Ring Ø1.78 x 60.05	2	42	9.803-144.0	Plunger Rod (4030, 4035, 5030, 6035)	3
6*	See Kits Below	U-Seal	3	29	8.933-011.0	Tapered Roller Bearing 2	2		9.803-145.0	Plunger Rod (3540)	3
7*	See Kits Below	Intermediate Ring	3	30	9.803-146.0	Crankshaft (5030,3540)	1	43	9.803-158.0	Connecting Rod	3
8*	See Kits Below	Back-up Ring	3		9.803-147.0	Crankshaft (4030,4035, 6035)	1	44	9.802-913.0	Snap Ring	6
9*	See Kits Below	U-Seal	3	31	9.803-167.0	Crankshaft Key	1	45	9.802-916.0	Connecting Rod Pin	3
10*	See Kits Below	Support Ring	3	32	9.802-921.0	Oil Dip Stick	1	46	9.803-218.0	Spring Washer	6
13	9.802-932.0	Manifold Head	1	33	9.803-140.0	Crankshaft Seal	1	47	9.803-238.0	Connecting Rod Screw	6
14*	See Kits Below	O-Ring Ø2.62 x 17.13	6	34	9.803-178.0	Shim	2	48	8.933-016.0	O-Ring, Ø2.62 x 126.67	1
15*	See Kits Below	Valve Assembly	6	35	8.717-209.0	Bearing Housing	1	49	9.803-165.0	Crankcase Cover	1
16*	See Kits Below	O-Ring Ø2.62 x 20.29	6	36*	See Kits Below	Plunger Bolt	3	50	9.803-197.0	O-Ring, Ø1.78 x 14	1
17	9.802-928.0	Valve Plug	6	37*	See Kits Below	Copper Spacer	3	51	9.803-202.0	Sight Glass 3/4	1
18	9.802-938.0	Manifold Stud Bolt	8	38*	See Kits Below	O-Ring Ø1.78 x 7.66	3	52	9.802-939.0	Cover Screw	5
19	9.802-884.0	Washer	16	39*	See Kits Below	Teflon Ring	3				
20	9.803-198.0	Copper Washer 3/8	1								
21	9.802-925.0	Brass Plug 3/8	1								

* Available in kit (See below)

REPAIR KITS

REPAIR KIT NO.	8.725-360.0	8.725-362.0	8.725-358.0	8.725-361.0	8.725-363.0	8.725-359.0	9.802-629.0	9.802-620.0	8.933-023.0	9.802-603.0	9.802-609.0
KIT DESCRIPTION	Plunger Seal 4035 6035 18mm	Plunger Seal 4030 5030 20mm	Plunger Seal 3540 15mm	Complete Seal Packing 4035 6035 18mm	Complete Seal Packing 4030 5030 20mm	Complete Seal Packing 3540 15mm	Plunger 4035 6035 18mm	Plunger 4030 5030 20mm	Plunger 3540 15mm	Complete Valve	Plunger Oil Seals
ITEM NUMBERS INCLUDED	4, 6, 8, 9, 10	4, 6, 8, 9, 10	4, 6, 8, 9, 10	4, 5, 6, 7, 8, 9, 10	4, 5, 6, 7, 8, 9, 10	4, 5, 6, 7, 8, 9, 10	36, 37, 38, 39, 40, 41	36, 37, 38, 39, 40, 41	36, 37, 38, 39, 40, 41	14, 15, 16	3
NO. OF CYLINDERS KIT WILL SERVICE	3	3	3	1	1	1	1	1	1	6	3