

FEATURES

- Designed and engineered exclusively for pressure washers.
- Seven year limited warranty.
- Forged brass manifold with an exclusive lifetime warranty.
- Die-cast, anodized aluminum oil-bath crankcase.
- Aluminum two piece connecting rods with lubrication channels for maximum life.
- Heavy-duty crankshaft bearings.
- Solid ceramic plungers with mirror finish and corrosion resistance.
- Stainless steel inlet and discharge valve assemblies.
- Forged valve caps with recessed O-rings to withstand high pressures.
- Dacromet® coated manifold bolts for extra corrosion resistance.
- Precision oil dipstick for proper ventilation of crankcase.
- Parker® low and high pressure U-Seals for long life performance.

**SPECIFICATIONS**

PUMP MODEL	KD-3025.1	KD-3030.1	KD-4020.1
Maximum Volume (GPM)	3	3	4.0
Max. Discharge Pressure (PSI)	2500	3000	2000
Maximum Pump Speed	1180	1650	1550
Maximum Inlet Pressure	125 PSI		
Maximum Inlet Vacuum	3 ft. water (2.6 in. HG)		
Bore	18 mm	15 mm	18 mm
Stroke	13.6 mm		
Crankcase Oil Capacity	14 oz.		
Maximum Fluid Temperature	185° F		
Inlet Port Thread	1/2-14 BSPP-F		
Discharge Port Thread	3/8-19 BSPP-F		
Shaft Diameter	24 mm		
Weight	16 lbs		
Dimensions (LxWxH)	8.5 x 8.4 x 5.0		

KD.1 Series Pump

9.803-417.0 KD 3025.1
 9.804-006.0 KD 3030.1
 9.804-019.0 KD 4020.1

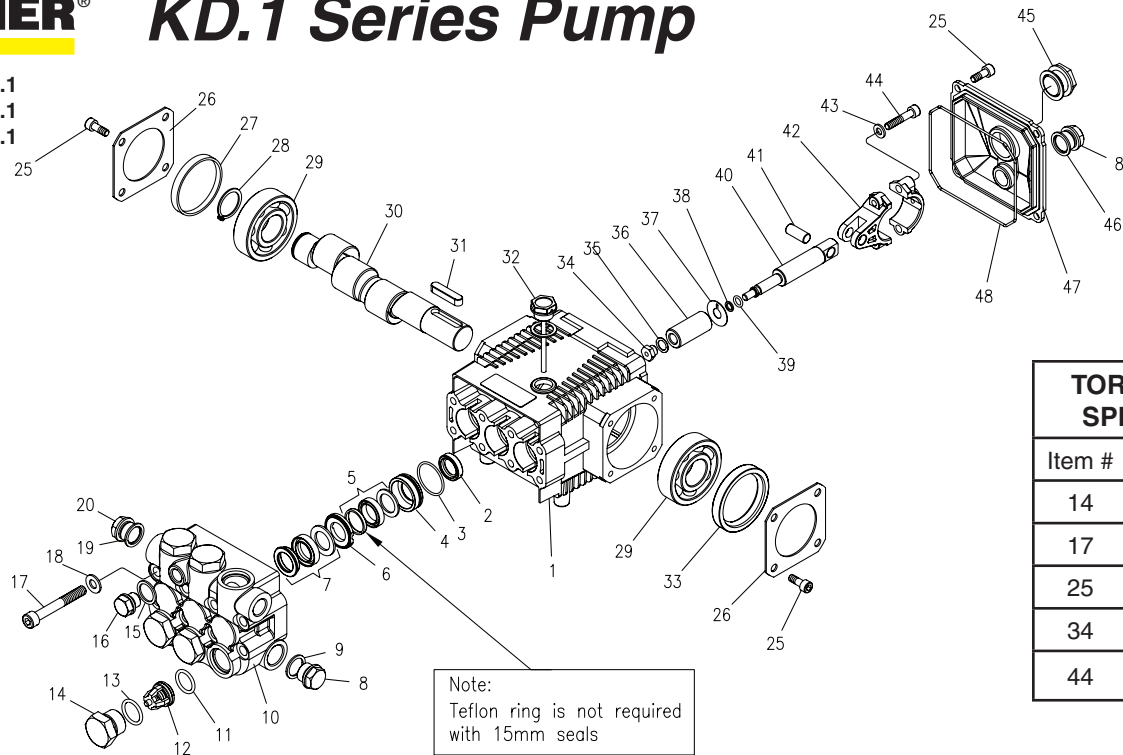

TORQUE SPECS	
Item #	Ft.-lbs
14	65
17	18
25	7.6
34	7
44	13

PARTS LIST

ITEM	PART NO.	DESCRIPTION	QTY	ITEM	PART NO.	DESCRIPTION	QTY	ITEM	PART NO.	DESCRIPTION	QTY
1	9.803-938.0	Crankcase	1	11*	See Kits Below	O-Ring Ø1.78 x 15.54	6	33	8.933-010.0	Crankshaft Seal	1
2*	See Kits Below	Plunger Oil Seal	3	12*	See Kits Below	Valve Assembly	6	34*	See Kits Below	Plunger Nut	3
3*	See Kits Below	O-Ring Ø1.78 x 28.30	3	13*	9.803-948.0	O-Ring Ø2.62 x 18.77	6	35*	See Kit Below	Copper Spacer	3
4*	See Kits Below	Pressure Ring 15mm (3030)	3	14	9.803-949.0	Valve Plug	6	36*	See Kits Below	Plunger, 15mm (3030)	3
	See Kits Below	Pressure Ring 18mm (4020, 3025)	3	15	9.803-950.0	Copper Washer 1/4	1		See Kits Below	Plunger, 18mm (4020, 3025)	3
5*	See Kits Below	U-Seal, 15mm (3030)	3	16	9.803-951.0	Brass Plug G1/4	1	37*	See Kits Below	Copper Spacer	3
	See Kits Below	U-Seal, 18mm (4020, 3025)	3	17	9.803-952.0	Manifold Stud Bolt	8	38*	See Kits Below	O-Ring Ø1.78 x 5.28	3
6*	See Kits Below	Intermediate Ring 15mm (3030)	3	18	9.802-884.0	Washer	8	39*	See Kits Below	Teflon Ring	3
	See Kits Below	Intermediate 18mm (4020, 3025)	3	19	9.803-198.0	Copper Washer 3/8	1	40*	See Kits Below	Plunger Rod	3
7*	See Kits Below	Intermed. Ring 15mm (3030)	3	20	9.802-925.0	Brass Plug 3/8	2	41	9.803-965.0	Connecting Rod Pin	3
	See Kits Below	Intermed. Ring 18mm (4020, 3025)	3	25	9.802-939.0	Screw	12	42	9.803-966.0	Connecting Rod	3
8	9.802-926.0	Brass Plug 1/2"	1	26	9.803-953.0	Bearing Cover	2	43	9.803-218.0	Spring Washer	6
9	9.803-199.0	Copper Washer 1/2"	1	27	9.803-954.0	Bearing Seal	1	44	8.933-020.0	Connecting Rod Screw	6
10	9.803-946.0	Manifold Housing	1	28	9.802-914.0	Snap Ring	1	45	9.803-202.0	Sight Glass	1
				29	9.803-955.0	Ball Bearing	2	46	9.803-197.0	Gasket	1
				30	9.803-956.0	Crankshaft	1	47	9.803-968.0	Crankcase Cover	1
				31	9.803-167.0	Crankshaft Key	1	48	9.803-969.0	O-Ring Ø2.62 x 107.62	1
				32	9.803-957.0	Oil Dipstick	1				

* Available in kit (See below)

REPAIR KITS

REPAIR KIT NUMBER	8.725-354.0	8.725-356.0	8.725-355.0	8.725-357.0	9.803-934.0	9.803-935.0	9.803-936.0	9.803-937.0
KIT DESCRIPTION	Plunger Seal 15mm 3030	Plunger Seal 18mm 3025 4020	Complete Seal Packing, 15mm 3030	Complete Seal Packing, 18mm 3025 4020	Plunger 15mm 3030	Plunger 18mm 3025 4020	Complete Valve	Plunger Oil Seals
ITEM NUMBERS INCLUDED	3, 5, 7	3, 5, 7	3, 4, 5, 6, 7	3, 4, 5, 6, 7	34, 35, 36, 37, 38, 39, 40	34, 35, 36, 37, 38, 39, 40	11, 12, 13	2
NUMBER OF CYLINDERS KIT WILL SERVICE	3	3	1	1	1	1	6	3