

#	PART NO	DESCRIPTION	QTY
1	7103577	ENGINE ASSY, HONDA GX390 (DH4240B)	1
2	7103576	PUMP ASSY, GP TX1510A (DH4240B)	1
2.1	7102207	SOAP HOSE AND FILTER KIT	1
† 2.2	7103180	PUMP GENERAL TX1510A	1
2.3	7100019	COUPLER, OUTLET 3/8 QC(F) x 3/8 NPT(F)	1
2.4	7100495	ADAPTER, INLET GHT(F) X 1/2 NPT(F)	1
2.5	7102470	PLUG, 3/8 NPT-M	1
2.6	7101331	THERMAL RELIEF VALVE 1/2 NPT(M)	1
3	7103380	FRAME ASSY., 21 x 15.25 (BLACK)	1
4	7103592	FRONT HANDLE ASSY.	1
4.1		FRONT HANDLE, (BLACK)	1
4.2		BOLT, FLANGE 5/16-18 X 2.00IN HHFB	4
4.3		NUT LOCK 5/16-18 REG NYLOCK	4
4.4		WASHER, 5/16 x 7/8 x .09	4
5	7103593	REAR HANDLE ASSY, DH4240B	1
5.1		REAR HANDLE (BLACK)	1
5.2	7103270	DECAL PANEL	1
5.3		BOLT, FLANGE 5/16-18 X 2.00IN HHFB	4
5.4	7100389	GROMMET, 7/16IN RUBBER	5
5.5		NUT LOCK 5/16-18 REG NYLOCK	4
5.6		WASHER, 5/16 x 7/8 x .09	4
5.7	7103264	SCREW, 1/4-20 X 0.75 TORX PAN HEAD	4
6	7100369	SUB FRAME 19.125 X 5.135	1
7	7101985	LEG CHANNEL	1
8	7103594	ENGINE MOUNT HARDWARE KIT	1
8.1		WASHER, 3/8 x 1.00	8
8.2		BOLT, 3/8-24 x 2.0 GR5	4
8.3		NUT, 3/8-24 NYLOCK	4
9	7103596	ENGINE ADJUSTING BLOCK KIT	1
9.1		ENGINE ADJUSTING BLOCK	1
9.2		WASHER .38 x .63 x .06	1
9.3		NUT, 3/8-16	2
9.4		BOLT, .375-16 x 2.5 HHCS FULL THREAD	1
9.5		WASHER 1/4" AN FLAT	4
9.6		BOLT, 1/4-28 x 1.50	2
9.7		NUT, LOCK 1/4-28 NYLOCK	2
10	7103595	PUMP MOUNTING KIT	1
10.1		PUMP MOUNTING BRACKET	1
10.2		PUMP BUMPER	1
10.3		BOLT, 5/16-18 x 1" HX HD GR5	4
10.4		WASHER FLAT 5/16 X .7 OD PLTD	8
10.5		NUT LOCK 5/16-18 REG NYLOCK	4
10.6		BOLT, B18.6.7M - M8 x 1.25 x 16MM	4
10.7		5/16IN SPLIT WASHER ZINC PLATED	4
11	7100173	BUSHING H X 1	1
11.1		FLANGE BUSHING, KEYED Hx1.0	1
11.2		BOLT, 5/16-18 x 1" HX HD GR5	2
12	7100174	BUSHING H X 24MM	1
12.1		FLANGE BUSHING, KEYED H X 24MM	1
12.2		BOLT, 5/16-18 x 1" HX HD GR5	2

#	PART NO	DESCRIPTION	QTY
13	7101997	PULLEY 2 3V500-H	2
14	7101998	BELT, 3V x 375	2
15	7103598	BELT GUARD ASSY.	1
15.1	7103379	BELTGUARD ASSY, FRONT 18IN FLAT BLACK	1
15.2		BOLT, 5/16-18 x 1 1/4" HX HD	2
15.3		WASHER, 5/16 x 7/8 x .09	4
15.4		BELTGUARD SPACER	2
15.5		GROMMET, 7/16 RUBBER	2
15.6		WASHER, SPLIT-LOCK 1/4IN	3
15.7		BOLT, 1/4-20 x 1.00 GR5	1
15.8		NUT LOCK 5/16-18 REG NYLOCK	2
15.9	7103378	BELTGUARD ASSY, BACK 18IN FLAT BLACK	1
16	7103599	BELT GUARD TENSIONER KIT	1
16.1		SCREW, 8MM SHLDR X 30MM X M6-1.0 SKT HD	1
16.2		SCREW, 10-32 X .50 PAN HEAD PHILLIPS	1
16.3		BOLT, 5/16-24 X 1.25 GR5	1
16.4		SPACER BACK	2
16.5		WASHER, FENDER 3/8 x 1.5 x .04	1
16.6		WASHER, BUMPER RUBBER	1
16.7		SPRING, BELT GUARD TENSIONER	1
16.8		NUT SPRING EYE	1
17	7103521	WHEEL KIT, 13.0 X 5.0-6 (BLACK)	2
17.1		COLLAR, LOCKING 5/8I.D.	2
17.2		WHEEL 13.0 x 5.0-6 BLACK	1
18	7103600	FOOT KIT, 1.250 TALL	2
18.1		NUT LOCK 5/16-18 REG NYLOCK	1
18.2		FOOT, RUBBER 2.00IN OD X 1.125IN 60 DURO	1
18.3		WASHER FLAT 5/16 X .7 OD PLTD	1
18.4		BOLT, 5/16-18 X 1 1/4 HX HD	1
18.5		WASHER 5/16" X 1.0" OD FENDER WASHER	1
19	7101683	NOZZLE SET, 5 PC. 4.0	1
20	7103240	GUN & WAND 5075PSI, 3/8 QC(M) X M22(F)	1
21	7103261	LANCE, 31" M22-M TO 1/4" QC-F	1
22	7103516	HOSE ASSY. 4500PSI 3/8 X 50FT	1
* 23	7103372	BOX, DH4240B	1
* 24	7103369	OWNER'S MANUAL, DH4240B	1

\* - NOT SHOWN

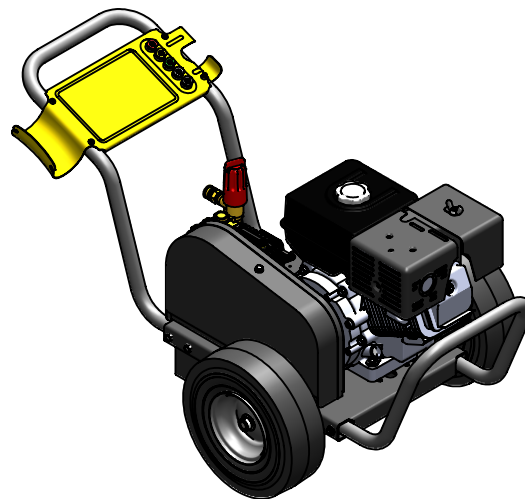

† The serial Number may contain optional unique identifier that indicates which Bill Of Materials is applicable to the unit. A Build code of "-1" indicates to use Bill Of Material on sheet 4 for pump. No unique identifier indicates to use Bill Of Material on sheet 1 for pump.

Sample Serial Number S/N = DH4240B - 4240 - 1

Model Number →

Unique identifier →

Optional Build Code →

UNLESS OTHERWISE SPECIFIED:		NAME	DATE	FNA-GROUP
DIMENSIONS ARE IN INCH [MM] TOLERANCES: ANGULAR: ±2deg TWO PL ±0.015 [.38] THREE PL ±0.005 [.13]	DRAWN	S. FERN.	4/1/2010	
	CHECKED	J. RABEY	4/1/2010	
	ENG APPR.	C. DEFR.	4/1/2010	
	MFG APPR.	C. CHISM	4/1/2010	
	Q.A.	J. PENUELAZ	4/1/2010	
MATERIAL	AS NOTED		COMMENTS:	
FINISH	N/A			
APPLICATION	DO NOT SCALE DRAWING			
PROPRIETARY AND CONFIDENTIAL		NEXT ASSY		USED ON
THE INFORMATION CONTAINED IN THIS DRAWING IS THE SOLE PROPERTY OF SIMPSON-DELCO. ANY REPRODUCTION IN PART OR AS A WHOLE WITHOUT THE WRITTEN PERMISSION OF SIMPSON-DELCO IS PROHIBITED.		SCALE: N/A		REV. B
		DWG. NO. 60446-S		REV. B
		SCALE: N/A WEIGHT: N/A		SHEET 1 OF 10

SOME PARTS REMOVED  
AND  
COLORS CHANGED FOR  
CLARITY

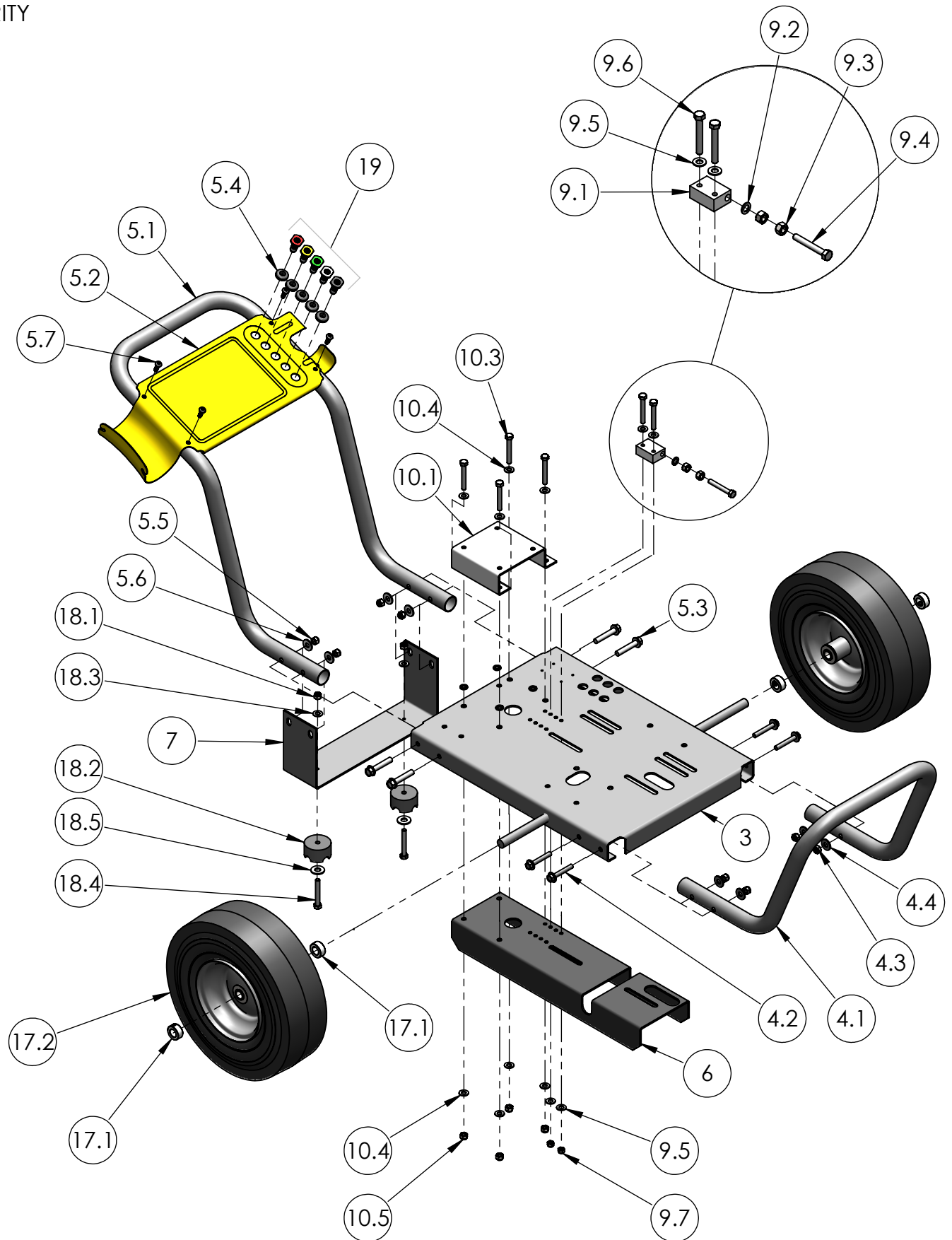

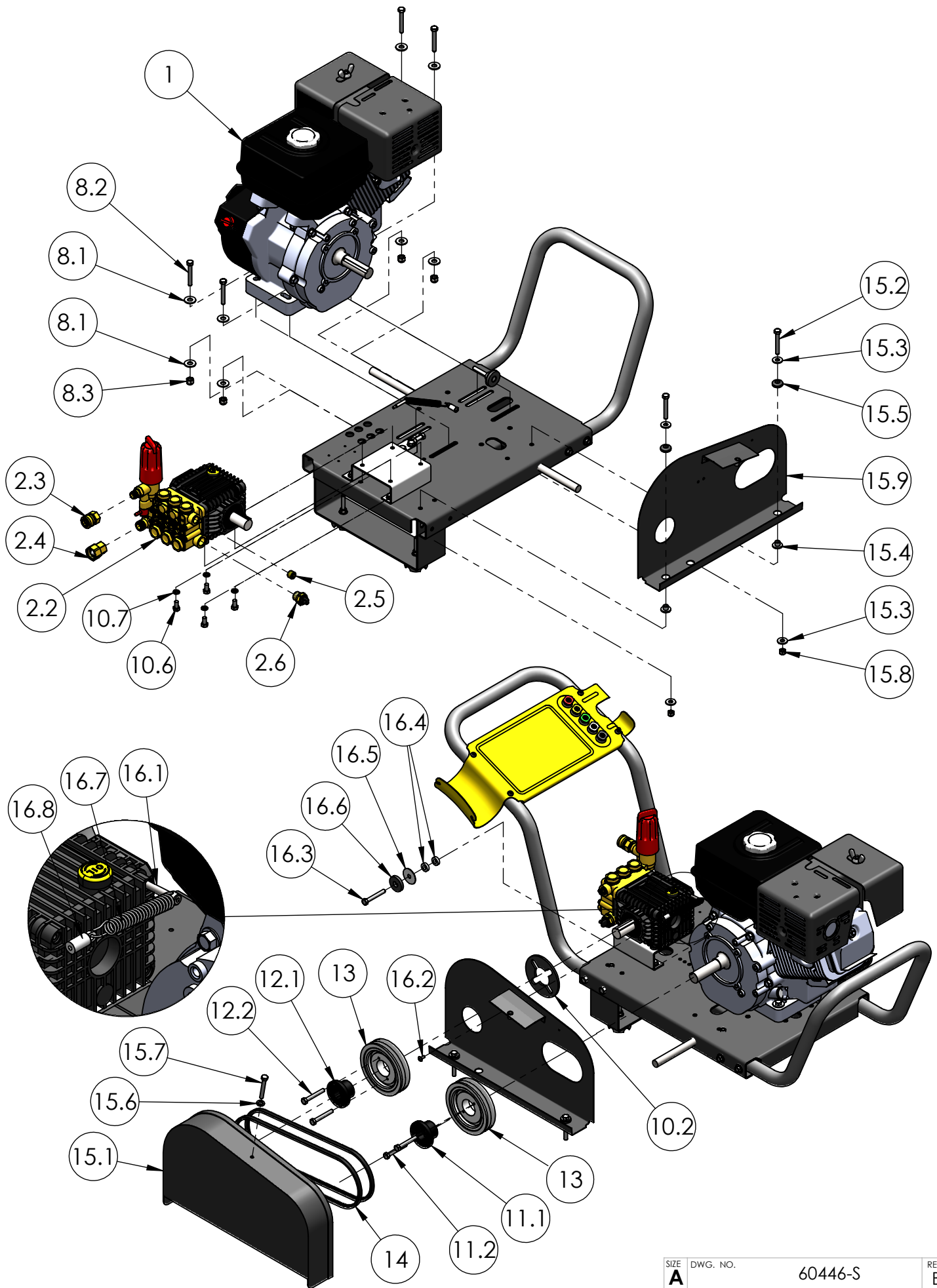

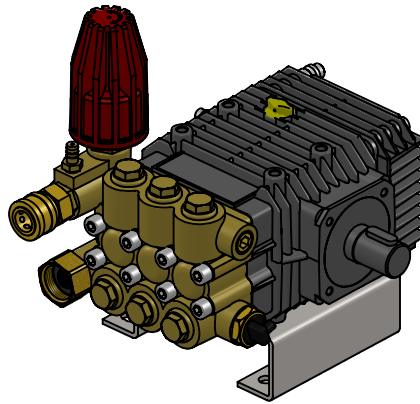

PUMP, 9.6WA15C SERVICE ASSEMBLY  
PART NO. 7104889

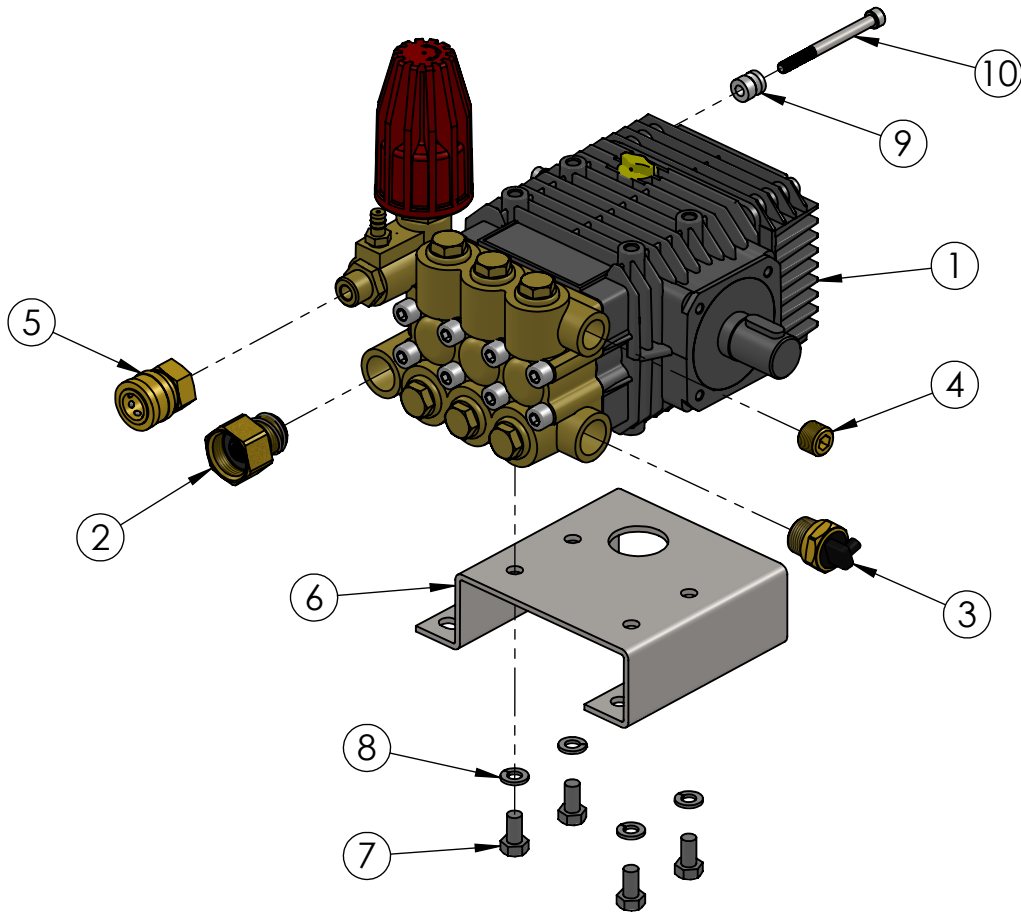

ITEM	PART NO.	DESCRIPTION	QTY
1	7104757	PUMP, 9.6WA15C	1
2	7100051	INLET ADAPTER, GARDEN-F TO .500 NPT-M	1
3	7101331	THERMAL RELIEF VALVE 1/2 NPT(M)	1
4	7102470	PLUG, 3/8 NPT(M)	1
5	7100019	COUPLER, OUTLET 3/8 QC(F) x 3/8 NPT(F)	1
6	7104838	BRACKET, PUMP HAT 9.6WA15C (18" BELT GUARD)	1
7		BOLT, M8-1.25 X 16 HHCS ZINC PLATED	4
8		WASHER, SPLIT LOCK 5/16 RUST RESISTANT	4
9		SPACER, SPRING LOCATOR COMET ALUMINUM	1
10		BOLT, M6-1.0 X 70MM SHCS ZINC PLATED	1



**OPTIONAL POWER TRANSMISSION KIT**  
 BELT & PULLEY KIT, 23V5.0 1610 24MM AND 1.00 BUSHINGS  
 Part No. 7105562

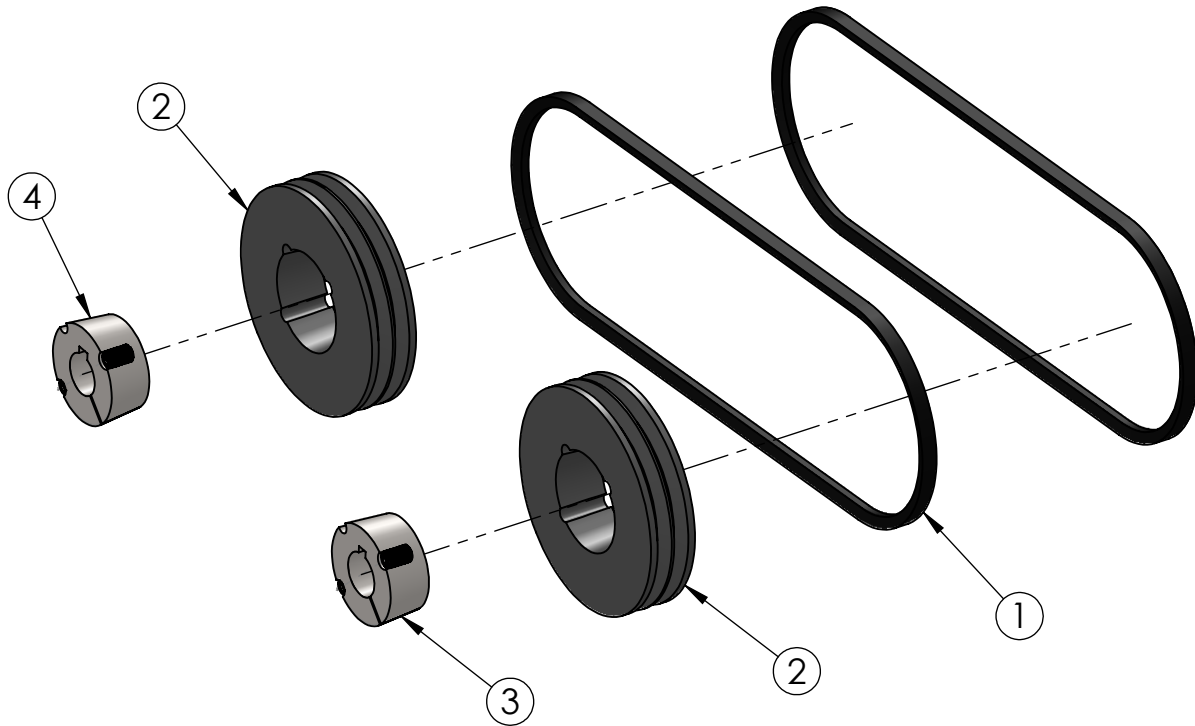

ITEM	PART NO.	DESCRIPTION	QTY.
1	7101998	BELT, 3V x 375	2
2	7105294	PULLEY, MARTIN 23V5.0 TAPER LOCK 1610	2
3	7105295	BUSHING, 1.00" I.D. TAPER LOCK 1610	1
4	7105296	BUSHING, 24MM I.D. TAPER LOCK 1610	1



GUN & WAND 5075PSI, 3/8 QC(M) X M22(F)  
PART NO. 7103240

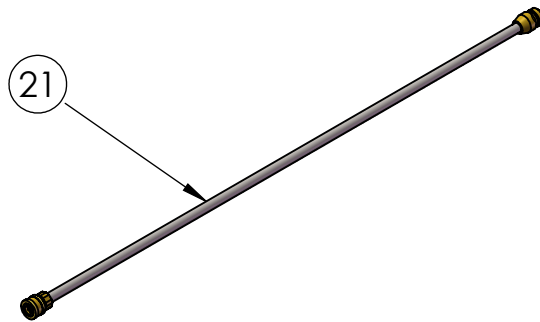

LANCE, 31" M22-M TO 1/4" QC-F  
PART NO. 7103261

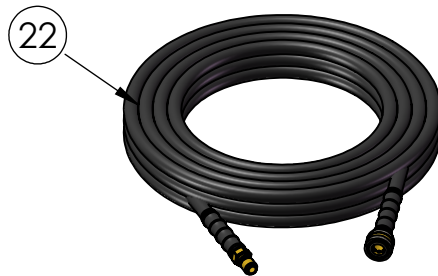

HOSE ASSEMBLY, 4500PSI 3/8 X 50FT  
PART NO. 7103516

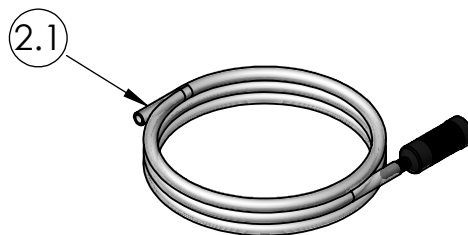

SOAP HOSE AND FILTER KIT  
PART NO. 7102207

# TX Series 63 UI

Direct Drive Triplex Plunger Pump

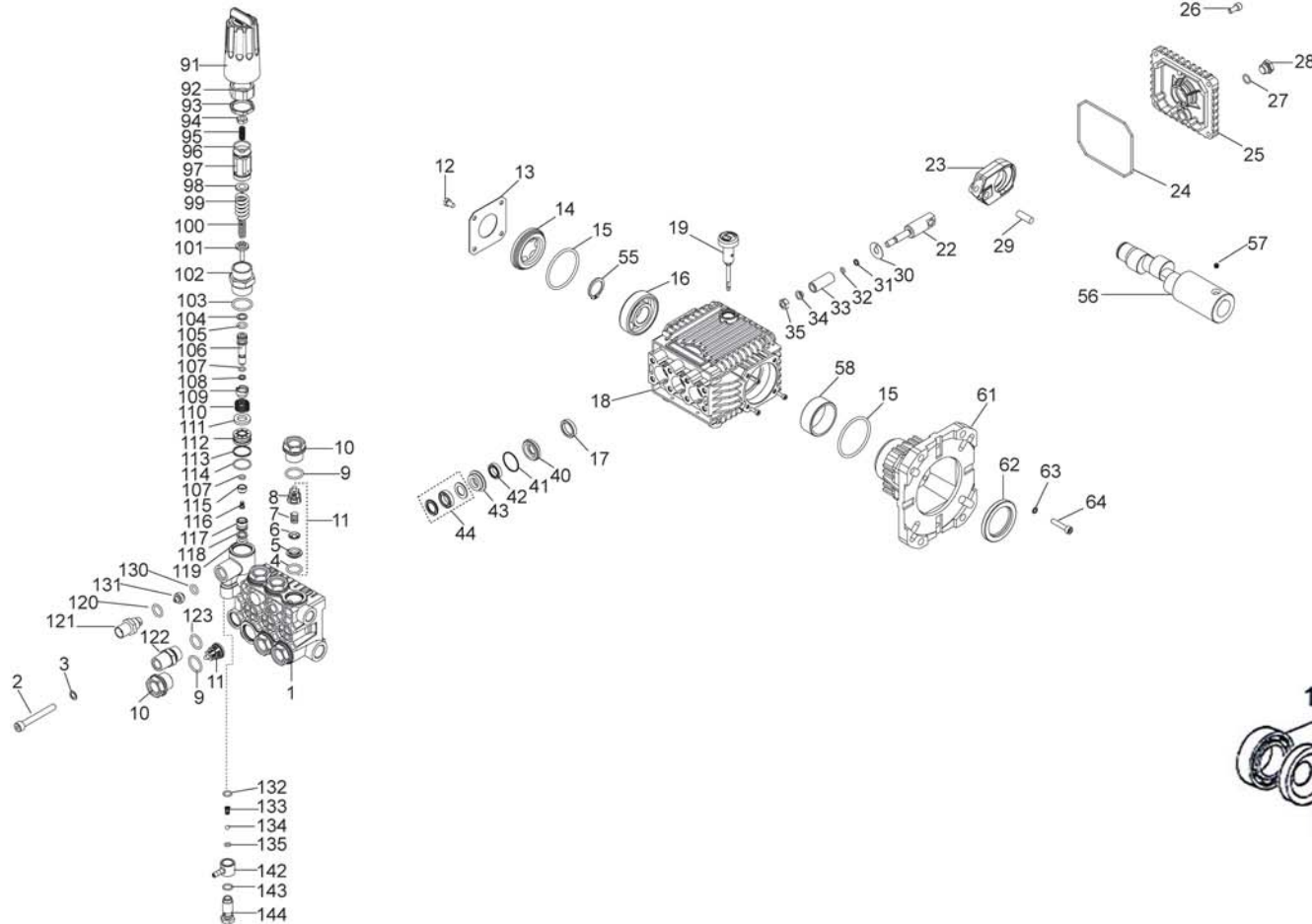

Solid Shaft  
Belt Drive Pump  
Components

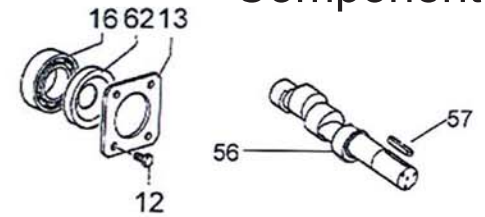

## REPAIR KITS

Kit No.	K123	K124	K159	K160	K166	K137	K235	K237
Items Included In Kit	4 - 8 (11)	9, 10	17	42, 44	40 - 44	104 - 119	91 - 103	132 - 144
Pc. In Kit	6	6	3	3	1	1	1	1

## TORQUE SPECS\*

Item	Ft/lb	Nm
2	14.7	20
10	73.7	100
12	7.3	10
26	7.3	10
28	14.7	20
35	11.0	15
64	7.3	10
121	29.5	40
122	29.5	40

\*Decrease torque by 20% if threads are lubricated.



## PART LIST

Item	Part no.	Description	Qty	Item	Part no.	Description	Qty	Item	Part no.	Description	Qty
1	7103434	Manifold, 15 mm, LH, NPT	1	43	NA	Int. Ring, 15mm	3	111	NA	Valve	1
2	7103435	Screw, M8 x 65	8	44	NA	Packing Assy, 15mm	3	112	NA	Valve guide	1
3	7103436	Lockwasher, M8.4	8	55	7103455	Retaining Ring	1	113	NA	O-ring	1
4	NA	O-ring	6	56	7103456	Crankshaft, 8mm (1")		114	NA	Anti-Ext ring	1
5	NA	Valve Seat	6		7103486	Crankshaft, 9mm (1")		115	NA	Spherical valve	1
6	NA	Valve Plate	6		7103457	Crankshaft, 10mm (1")		116	NA	Screw	1
7	NA	Spring	6		7103678	Crankshaft, 10mm (Solid Shaft)		117	NA	Seat	1
8	NA	Valve Cage	6	57	7103458	Screw, M6 x 6	1	118	NA	O-ring	1
9	NA	O-ring	6	57	7103881	Key, Crankshaft (Solid Shaft)	1	119	NA	Anti-Ext ring	1
10	NA	Valve Cap	6	58	7103459	Roller bearing	1	120	7103464	O-ring	1
11	NA	Valve Assembly	6	61	7103460	Flange 1", gas engine	1	121	7103465	Nipple, Disch - 3/8"NPT-M	1
12	7103437	Screw, M6 x 10	8	62	7103461	Oil Seal	1	122	7103466	Inlet Fitting	1
13	7103438	Bearing Cover	1		7103679	Oil Seal (Solid Shaft)		123	7103487	O-ring	1
14	7103439	Oil Level Indicator	1	63	7103462	Washer	4	130	7103467	O-ring	1
15	7103440	O-ring	2	64	7103463	Screw, M6 x 30	4	131	7103468	Nozzle 2.2mm	1
16	7103441	Ball Bearing	1	91	NA	Handle (Black)	1	132	7103469	O-ring	1
17	NA	Oil Seal	3	92	NA	Locking sleeve	1	133	7103470	Conical spring	1
18	7103442	Crankcase	1	93	NA	Locking nut	1	134	7103471	Ball	1
19	7103443	Oil Dip Stick	1	94	NA	Nut	1	135	7103472	O-ring	1
22	7103483	Plunger Guide	3	95	NA	Set screw	1	142	7103473	Fixed Injector	1
23	7103484	Connecting Rod	3	96	NA	O-ring	1	143	NA	O-ring	1
24	7103444	O-ring, Cover	1	97	NA	Regulator knob	1	144	7103474	Banjo bolt, Injector	1
25	7103485	NEW Rear Crankcase Cover	1	98	NA	Spring seat	1				
26	7103445	Screw, M6 x 14	4	99	NA	Spring (3500 PSI)	1	K123	7103475	Valve Kit (4-8)	
27	7103446	O-ring	1	100	NA	Spring	1	K124	7103476	Valve Cap Kit (9, 10)	
28	7103447	Plug, 1/4" G	1	101	NA	Stem	1	K159	7103478	Oil Seal Kit (17)	
29	7103448	Connecting Rod Pin	3	102	NA	Guide bushing	1	K160	7103479	Short Seal Kit (42, 44)	
30	7103449	Flinger Washer	3	103	NA	O-ring	1	K166	7103480	Long Seal Kit (40-44)	
31	7103450	Anti-extrusion Ring	3	104	NA	Anti-Ext ring	1	K137	7103477	By-Pass Kit (Lower 104-119)	
32	7103451	O-ring	3	105	NA	O-ring	1	K235	7103481	By-Pass Kit (Upper 91-103)	
33	7103452	Ceramic Plunger, 15mm	3	106	NA	Sleeve	1	K237	7103482	Injector Kit (132-144)	
34	7103453	Bushing	3	107	NA	O-ring	2				
35	7103454	Nut, M8	3	108	NA	Anti-Ext ring	1				
40	NA	Seal Retn'r, 15mm	3	109	NA	Spacer	1				
41	NA	O-ring	3	110	NA	Spring	1				
42	NA	Seal, LP, 15mm	3								

NOTE: All "NA" Parts are only available in Kits







# PUMP DIAGRAM

9.6WA15C, 9.6GA15C, 8.3GA15C

Engineered by FNA Group  
Elk Grove Village, IL 60007

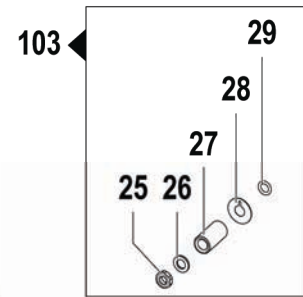
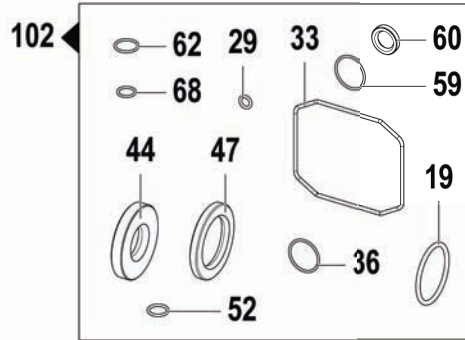
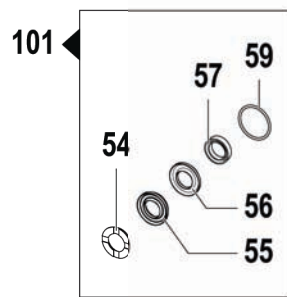
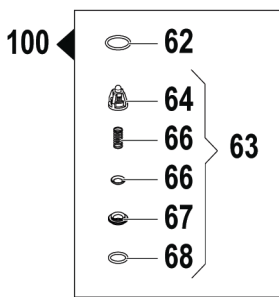
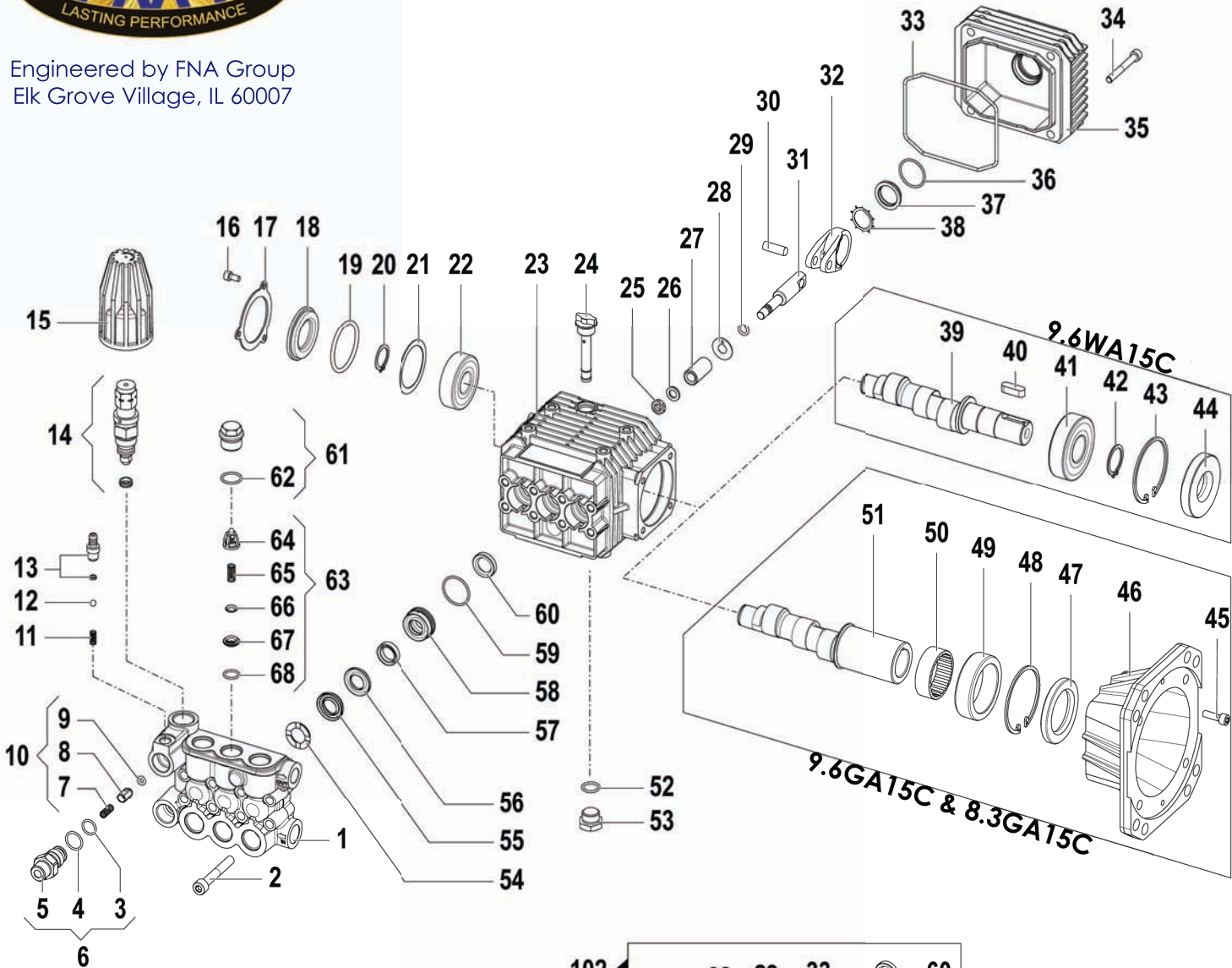

Pumps Covered By This Document	
Part No.	Model
7104757	9.6WA15C
7104820	9.6GA15C
7104858	8.3GA15C

Torque Specifications						
No.	Part No.	Description	lb.-ft	lb.in	N.m	Apply To Thread
2	7105403	M8 x 55 Screw	18.4	220	25	-
16	7105412	M5 x 10 Screw	3.0	40	4	-
25	-	Piston Nut	4.4	50	6	Loctite 243
34	7105425	M6 x 50 Screw	6.6	80	9	-
45	7105436	M6 x 20 Screw	6.6	80	9	-
61	7105446	Valve Plug	33.2	400	45	Loctite 243

# PUMP COMPONENTS

## 9.6WA15C, 9.6GA15C, 8.3GA15C

DWG NO.	PART NO.	DESCRIPTION	QTY.	MODELS
1	7105402	BRASS PUMP MANIFOLD, Ø15mm	1	ALL
2	7105403	SCREW, M8 X 55mm	8	ALL
3	-	O-RING, Ø1.75 X 12.42mm	1	ALL
4	-	O-RING, Ø1.78 X 15.6mm	1	ALL
5	-	INJECTOR BODY, Ø2mm-3/8" NPT(M)	1	ALL
6	7105404	INJECTOR BODY KIT, Ø2mm3/8" NPT(M)	1	ALL
7	-	SPRING	1	ALL
8	-	CHECK VALVE	1	ALL
9	7105405	O-RING, Ø2.4 X 4.3mm	1	ALL
10	7105406	CHECK VALVE KIT	1	ALL
11	7105407	DETERGENT SPRING	1	ALL
12	7105408	DETERGENT BALL	1	ALL
13	7105409	DETERGENT COUPLING	1	ALL
14	7105410	UNLOADER VALVE KIT, 3600PSI[250BAR]	1	ALL
15	7105411	UNLOADER ADJUSTMENT KNOB	1	ALL
16	7105412	SCREW, M5 X 10mm	3	ALL
17	7105413	CRANKCASE FLANGE	1	ALL
18	7105414	ALUMINUM END COVER	1	ALL
19	7105415	O-RING, Ø3.53 X 44.04mm	1	ALL
20	7105416	EXTERNAL SNAP RING, Ø20mm C72	1	ALL
21	7105417	SPACER, Ø41 X 51.8 X 0.5mm	1	ALL
22	7105418	BALL BEARING, Ø20 X 52 X 15mm	1	ALL
23	7105419	PUMP CRANKCASE	1	ALL
24	7105420	OIL DIPSTICK	1	ALL
25	-	SPECIAL NUT	3	ALL
26	-	WASHER, Ø8.2 X 14 X 1.5mm	3	ALL
27	-	CERAMIC BUSHING, Ø15mm	3	ALL
28	-	WASHER	3	ALL
29	-	O-RING, Ø1.78 X 6.07mm	3	ALL
30	7105421	PISTON PIN	3	ALL
31	7105422	PISTON GUIDE	3	ALL
32	7105423	CONNECTING ROD ASSEMBLY	3	ALL
33	7105424	O-RING, Ø3.0 X 94mm	1	ALL
34	7105425	SCREW, M6 X 50mm	4	ALL
35	7105426	CRANKCASE COVER	1	ALL
36	7105427	O-RING, Ø1.78 X 23.25mm	1	ALL
37	7105428	OIL LEVEL SIGHT GLASS	1	ALL
38	7105429	SIGHT GLASS RETAINING RING, Ø28mm	1	ALL
39	7105430	CRANKSHAFT, Ø24 X 9.6mm	1	9.6WA15C ONLY
40	7105431	SHAFT KEY, 8 X 7 X 25mm	1	9.6WA15C ONLY
41	7105432	BALL BEARING, Ø25 X 62 X 17mm	1	9.6WA15C ONLY
42	7105433	EXTERNAL SNAP RING, Ø25mm C72	1	9.6WA15C ONLY
43	7105434	INTERNAL SNAP RING, Ø62mm C72	1	9.6WA15C ONLY
44	7105435	OIL SEAL, Ø25 X 62 X 10/7mm	1	9.6WA15C ONLY
45	7105436	SCREW, M6 X 20mm	4	8.3GA15C & 9.6GA15C
46	7105437	MOUNTING FLANGE, 1.00"	1	8.3GA15C & 9.6GA15C
47	7105438	OIL SEAL, Ø40 X 62 X 7mm	1	8.3GA15C & 9.6GA15C
48	7105434	INTERNAL SNAP RING, Ø62mm C72	1	8.3GA15C & 9.6GA15C
49	7105439	BUSHING	1	8.3GA15C & 9.6GA15C
50	7105440	ROLLER BEARING, Ø40 X 47 X 16mm	1	8.3GA15C & 9.6GA15C
51	7105441	CRANKSHAFT, Ø1.00" X 8.3mm	1	8.3GA15C
51	7105442	CRANKSHAFT, Ø1.00" X 9.6mm	1	9.6GA15C
52	7105443	O-RING, Ø2 X 14mm	1	ALL
53	7105444	CAP, 3/8" GAS PIPE THREAD	1	ALL
54	-	PACKING HEAD RING, Ø15mm	3	ALL
55	-	PACKING, Ø15mm	3	ALL
56	-	BACK RING, Ø15mm	3	ALL
57	-	PACKING, Ø15 X 22 X 5.5mm	3	ALL
58	-	PACKING RETAINER, Ø15mm	3	ALL
59	-	O-RING, Ø1.78 X 26.7mm	3	ALL
60	7105445	OIL SEAL, Ø15 X 24 X 5mm	3	ALL
61	7105446	PLUG AND O-RING KIT	6	ALL
62	7105447	O-RING, Ø1.78 X 17.17mm	6	ALL
63	-	SUCTION/PRESSURE VALVE ASSEMBLY KIT	6	ALL
64	-	SUCTION/PRESSURE VALVE CAGE	6	ALL
65	-	VALVE SPRING	6	ALL
66	-	SUCTION/PRESSURE VALVE	6	ALL
67	-	SUCTION/PRESSURE VALVE SEAT	6	ALL
68	-	O-RING, Ø1.78 X 12.42mm	6	ALL
SPARE PARTS KITS				
100	7105448	SUCTION/PRESSURE VALVE KIT	1	ALL
101	7105449	WATER SEAL KIT	1	ALL
102	7105450	OIL SEAL KIT	1	ALL
103	7105451	PISTON KIT, Ø15mm	1	ALL