

**Spare parts list**  
**(5.958-613.0) Spare parts list K 2300 G**

## DE HINWEISE

### Weitere Sprachen:

Diese Ersatzteilliste ist in weiteren Sprachen erhältlich. Sie erhalten diese unter [www.kaercher.com](http://www.kaercher.com) im Bereich Service.  
Die Schreibweise der Teilenummer, z.B. 75456380, entspricht der Teilenummer 7.545-638.0.

### Mengenangaben:

Die Mengenangaben in der Ersatzteilliste entsprechen den in der Baugruppe verbauten Stückzahlen der Bauteile.

### Meterware:

Ersatzteile welche als Meterware geliefert werden sind auf Einbaulänge selbst zu kürzen. Die Stückzahlen sind als Mindestbestellmenge =1m angegeben und müssen je nach Bedarf auf weitere volle Meterzahlen erhöht werden.

### Versionen/ Werknummern:

Sind Versionen oder Werknummern in der Ersatzteilliste angegeben, ist anhand dieser vor Bestellung zu prüfen, welches Bauteil für ihr Gerät verwendet werden muss.

### Lackierte Teile:

Bei Bestellungen von lackierten Teilen welche in der Ersatzteilliste nicht in verschiedenen Farben ausgewiesen sind, ist zusätzlich die Farbnummer oder Farbe mit anzugeben.

### Technische Änderungen:

Technische Änderungen sowie das Recht der ausschließlichen Auswertung unseres geistigen Eigentums behalten wir uns vor.

## EN INSTRUCTIONS

### Other languages:

This list of spare parts is also available in other languages. You can get this list from [www.kaercher.com](http://www.kaercher.com) in the Service division.  
The designation of the part number e.g. 75456380 is equal to 7.545-638.0.

### Quantity details:

The quantity details in the spare parts list correspond to the number of pieces of the component installed in the assembly group.

### Piece goods:

Spare parts that are sold as piece goods are to be cut to the desired length. The quantities have been indicated as minimum order quantity =1m and must be rounded off to the full meter figure depending on your requirements.

### Version/ Plant numbers:

If version or plant numbers are mentioned in the spare parts list, then use the same to check before ordering which spare part needs to be used for your appliance.

### Painted parts:

While ordering painted parts that are not mentioned in the spare parts list in their colour variations, please mention the colour number or the colour you require.

### Technical changes:

We reserve the right to make technical changes as well as the right to exclusive use of our intellectual property.

## FR REMARQUES

### Autres langues:

Cette liste de pièces de rechange est disponible en autres langues. Cela est disponible sous [www.kaercher.com](http://www.kaercher.com) dans le menu Service.  
La désignation du numéro de pièce, par ex. 75456380, correspond au numéro de pièce 7.545-638.0.

### Indications de quantité:

Les indications de quantité dans la liste de pièces de rechange correspondre aux nombres de pièces des composant utilisées dans la construction.

### Matériel au mètre:

Les pièces de rechange qui sont livrées au mètre doivent être raccourcies à longueur souhaitée par l'acheteur même. Les nombres des pièces sont indiquées en quantité de commande minimale = 1m et doivent être augmentés selon le besoin à une chiffre de mètre complète.

### Versions/ Numéros d'usine:

Lorsqu'il sont indiquées des versions ou des numéros d'usine dans la liste de pièces de rechange, vous devez vérifier que composant doit être utilisé pour votre appareil.

### Pièces laquées:

Pour commander des pièces laquées, où les différentes couleurs ne sont pas indiquées dans la liste des pièces de rechange, vous devez indiquer en plus le numéro de la couleur ou seulement la couleur.

### Modifications techniques:

Nous nous réservons la possibilité des modifications techniques ainsi le droit d'exploitation exclusive de notre propriété intellectuelle.

## IT AVVERTENZE

### Altre lingue:

Il presente elenco di parti di ricambio è disponibile sul nostro sito Web anche in altre lingue: sotto [www.kaercher.com](http://www.kaercher.com) alla voce "Service".

L'indicazione del codice pezzo, ad es. 75456380, corrisponde al codice pezzo 7.545-638.0

### Indicazioni di quantità:

Le indicazioni di quantità riportate dall'elenco "parti di ricambio" corrispondono al numero delle singole componenti contenute nella rispettiva unità.

### Merce a metro:

Le parti di ricambio fornite come "merce a metro" devono venire in seguito accorciate alla lunghezza necessaria per il montaggio. La quantità unitaria è indicata come "quantità minima di ordinazione = 1m" e deve all'occorrenza venire moltiplicata per il numero intero di metri necessari.

### Versioni / Numeri di fabbricazione:

Quando l'elenco "parti di ricambio" riporta diverse versioni o numeri di fabbricazione, confrontare la versione o il numero di fabbricazione del ricambio desiderato con quelle/i presenti nell'elenco e indicarla/o al momento dell'ordinazione.

### Parti di ricambio verniciate:

Nel caso di ricambi verniciati, se l'elenco parti di ricambio non ne riporta espressamente i diversi colori, al momento dell'ordinazione è necessario indicare anche il colore o il numero del colore desiderato.

### Modifiche tecniche:

Ci riserviamo il diritto di apportare modifiche tecniche così come il diritto di utilizzo esclusivo della nostra proprietà intellettuale.

## ES INDICACIONES

### Otros idiomas:

La lista de piezas de repuesto se puede adquirir en otros idiomas. La puede adquirir en [www.kaercher.com](http://www.kaercher.com) en el área de servicios.

La notación de los números de las piezas, p.ej. 75456380 corresponde al número de pieza 7.545-638.0.

### Cantidades:

Las indicaciones de cantidades de la lista de piezas de repuesto corresponden al número de piezas montadas en el componente.

### Mercancía por metros:

Las piezas de repuesto que se suministran por metros se pueden cortar al largo deseado. La unidad mínima de pedido es de = 1 m y el número de metros completos se puede aumentar según necesidad.

### Versiones/números de fábrica:

Si se indica la versión o número de fábrica en la lista de piezas de repuesto, se debe comprobar en ella la pieza a usar para su aparato antes de realizar el pedido.

### Piezas lacadas:

Al realizar pedidos de piezas lacadas que no estén indicadas en los diferentes colores en la lista de piezas de repuesto, se debe indicar también la referencia del color o el color.

### Modificaciones técnicas:

Reservados los derechos de realizar modificaciones técnicas y aprovechar nuestra propiedad intelectual.

## PL WSKAZÓWKI

### Pozostałe języki:

Ta lista części zamiennych jest dostępna w także w innych językach. Mogą ją Państwo pobrać ze strony [www.kaercher.com](http://www.kaercher.com) w dziale Serwis.

Sposób zapisywania numeru części, np. 75456380, odpowiada numerowi części 7.545-638.0.

### Dane ilości:

Dane ilości podane w liście części zamiennych odpowiadają liczbie sztuk podzespołów tworzących dany moduł.

### Towar sprzedawany na metry:

Części zamienne dostarczane jako towar sprzedawany na metry po zamontowaniu należy samodzielnie skrócić do potrzebnej długości. Liczba sztuk podana jest jako minimalna ilość zamówienia = 1m i w zależności od potrzeb zwiększa się ją o kolejne pełne metry.

### Wersje/ Numer zakładu:

Jeżeli w liście części zamiennych podane są wersje lub numery zakładu, przed zamówieniem na ich podstawie należy sprawdzić, który podzespół stosuje się w Państwa urządzeniu.

### Części lakierowane:

W przypadku zamówień części lakierowanych, które w liście części zamiennych nie podano w wielu kolorach, należy dodatkowo zaznaczyć nr koloru lub kolor.

### Zmiany techniczne:

Zastrzegamy sobie prawo do zmian technicznych oraz wyłącznego wykorzystywania naszej własności intelektualnej.

## **RU УКАЗАНИЯ:**

### **Другие языки:**

Данный список запасных частей также доступен на других языках. Вы найдете его на сайте [www.kaercher.com](http://www.kaercher.com) в разделе Service  
Маркировка номера детали, например, 75456380, соответствует номеру детали 7.545-638.0.

### **Указание количества:**

Количественные данные в списке запасных частей соответствуют числу компонентов, входящих в состав узлов.

### **Товар, продаваемый на метры:**

Запасные части, продающиеся на метры, необходимо обрезать до нужной длины. Число изделий указано в виде минимального объема заказа = 1м и их количество можно округлить до требуемого по мере необходимости.

### **Варианты исполнения/заводские номера:**

Если варианты исполнения или заводские номера указаны в списке запасных частей, то перед заказом необходимо проверить, какая деталь подходит для вашего устройства.

### **Лакированные детали:**

При заказе лакированных деталей, варианты расцветки которых не указаны в списке запасных частей, необходимо дополнительно указать номер цвета или необходимый для вас цвет.

### **Технические изменения:**

Мы оставляем за собой право на технические изменения, а также право на исключительное использование нашей интеллектуальной собственности.

## Table of contents

---

<b>Spare parts list K 2300 G (5.958-613.0)</b> .....	<b>6</b>
10 Individual parts (0.102-603.0).....	7
11 Individual parts (0.102-604.0).....	8
12 Base frame (0.102-605.0).....	10
20 Pump set (0.107-512.0).....	12
21 Valves (0.107-406.0).....	13
17 Spare part set chemistry (2.883-862.0).....	15
100 SPARE PARTS KIT fuer Pumpensatz (2.884-214.0).....	16
22 Piston (0.107-408.0) .....	17
23 Piston (0.107-473.0) .....	19
30 Motor (0.112-596.0) .....	21
31 Motor (0.125-049.0).....	22
32 Motor (0.112-597.0).....	24
34 Transmission (0.112-611.0) .....	26
40 Accessories (0.147-896.0).....	28
41 Hand trigger gun (0.148-122.0).....	29
42 Triple jet nozzle (0.146-720.0) .....	31
43 Triple jet nozzle (0.103-784.0) .....	33

Spare parts list K 2300 G (5.958-613.0)

---

Pos	Material #	Name	Qty.	Unit	from ser.nr.	up to ser.nr.
10	0.102-603.0	Individual parts	1.000	ST	0000000000	0000000000
20	0.107-512.0	Pump set	1.000	ST	0000000000	0000000000
30	0.112-596.0	Motor	1.000	ST	0000000000	0000000000
40	0.147-896.0	Accessories	1.000	ST	0000000000	0000000000

**10 Individual parts (0.102-603.0)**

---

Pos	Material #	Name	Qty.	Unit	from ser.nr.	up to ser.nr.
11	0.102-604.0	Individual parts	1.000	ST	0000000000	0000000000
12	0.102-605.0	Base frame	1.000	ST	0000000000	0000000000

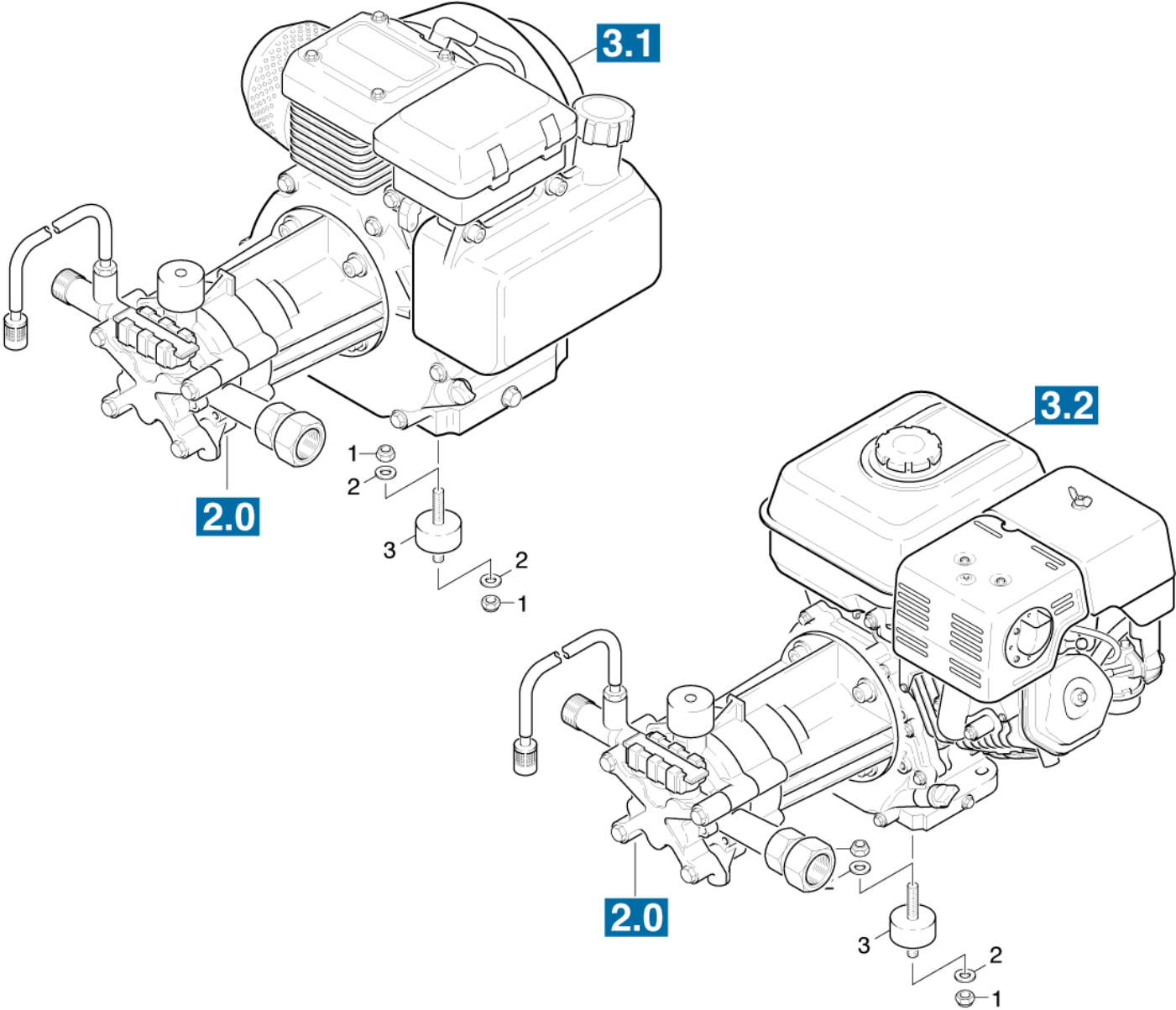



11 Individual parts (0.102-604.0)

---

ET/VT (spare/wear parts)	Pos	Material #	Name	Qty.	Unit	from ser.nr.	up to ser.nr.
	1	9.197-002.0	5/16-18 NE NYLON INSERT L/N ZC 5UM	8.000	ST	0000000000	0000000000
X-X	2	7.312-004.0	Washer 8 -200HV-A3E ISO 7090	8.000	ST	0000000000	0000000000
	3	9.183-403.0	RUBBER DAMPENER DIA.35x16	4.000	ST	0000000000	0000000000

---

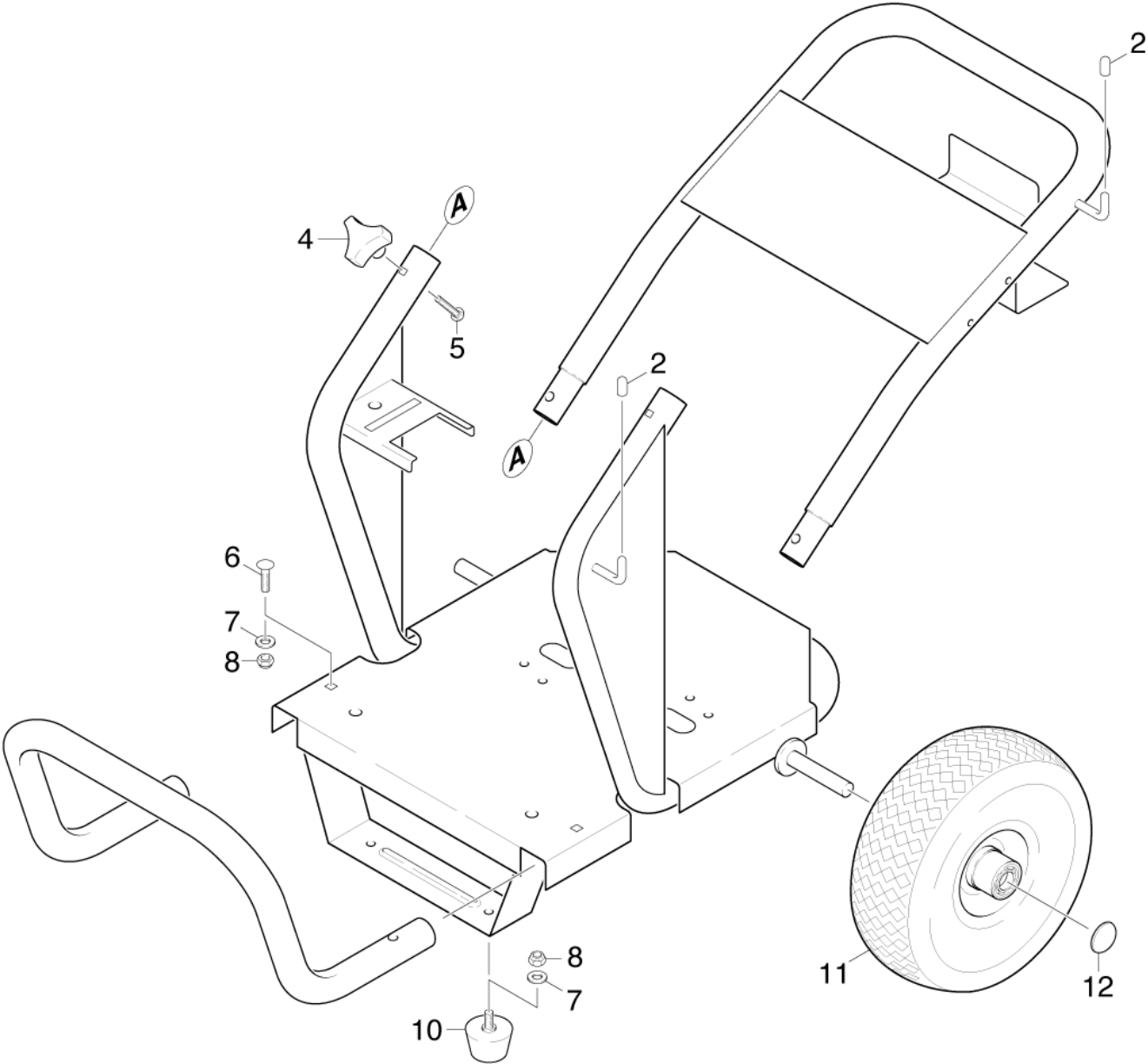

**12 Base frame (0.102-605.0)**

ET/VT (spare/wear parts)	Pos	Material #	Name	Qty.	Unit	from ser.nr.	up to ser.nr.
	2	9.183-103.0	RUBBER CAP DIA.5/16"x 3/4"	2.000	ST	0000000000	0000000000
	4	9.182-354.0	Star grip	2.000	ST	0000000000	0000000000
	5	9.196-304.0	CARRIAGE BOLT 5/16"-18x1.50"BLACK	2.000	ST	0000000000	0000000000
	6	9.196-305.0	CARRIAGE BOLT 5/16"-18x2.00"BLACK	2.000	ST	0000000000	0000000000
X-X	7	7.312-004.0	Washer 8 -200HV-A3E ISO 7090	12.000	ST	0000000000	0000000000
	8	9.197-002.0	5/16-18 NE NYLON INSERT L/N ZC 5UM	12.000	ST	0000000000	0000000000
	10	9.183-401.0	Rubber buffer	2.000	ST	0000000000	0000000000
	11	9.189-007.0	WHEEL 10" X 3.50" PNEU	2.000	ST	0000000000	0000000000
	12	9.182-004.0	Cap	2.000	ST	0000000000	0000000000

**20 Pump set (0.107-512.0)**

---

Pos	Material #	Name	Qty.	Unit	from ser.nr.	up to ser.nr.	var. information
21	0.107-406.0	Valves	1.000	ST	0000000000	0000000000	
22	0.107-408.0	Piston	1.000	ST	0000000000	0000000000	VERSION 1
23	0.107-473.0	Piston	1.000	ST	0000000000	0000000000	VERSION 2

---

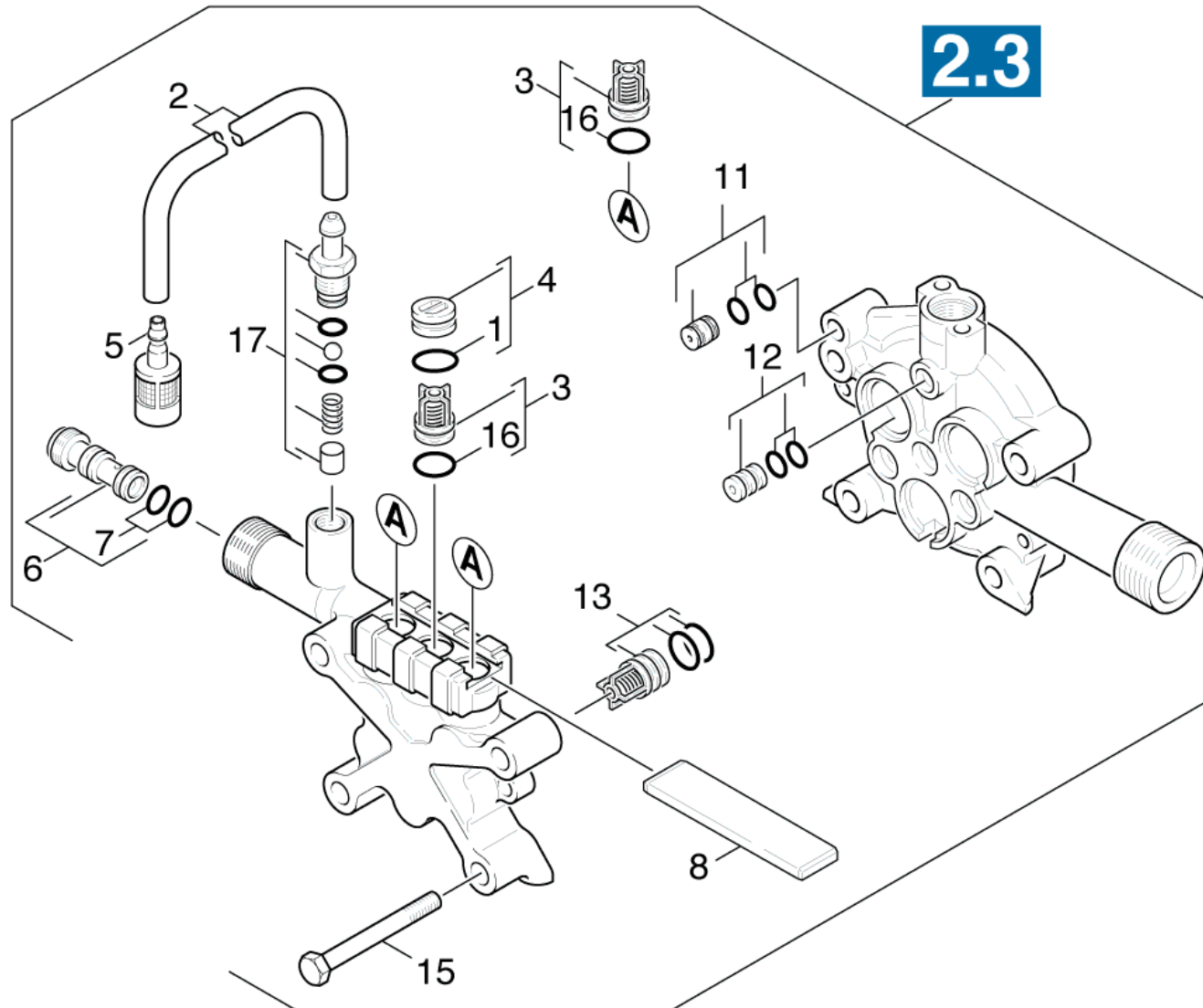

21 Valves (0.107-406.0)

ET/VT (spare/wear parts)	Pos	Material #	Name	Qty.	Unit	from ser.nr.	up to ser.nr.	Footnote text
	1	6.363-273.0	O-Ring seal 11,0 x 2,0	3.000	ST	0000000000	0000000000	
	2	6.388-216.0	Hose DN 5	3.000	M	0000000000	0000000000	TO ORDER AS CUT GOODS
X-X	3	2.884-916.0	Valve (3 Stück)	1.000	ST	0000000000	0000000000	
X-X	4	4.132-007.0	Drain plug only for replacement	3.000	ST	0000000000	0000000000	
	5	4.862-032.0	Filter chemistry regulation	1.000	ST	0000000000	0000000000	
	6	4.769-032.0	Nozzle insert	1.000	ST	0000000000	0000000000	
X-X	7	6.362-384.0	O-Ring seal 9x1,5 - NBR 70	2.000	ST	0000000000	0000000000	
	8	5.003-062.0	Plate	1.000	ST	0000000000	0000000000	
	11	4.030-109.0	Throttle complete	1.000	ST	0000000000	0000000000	
	12	4.030-125.0	Joining piece only for replacement	1.000	ST	0000000000	0000000000	
X-X	13	4.580-330.0	Suction valve complete	3.000	ST	0000000000	0000000000	
	15	7.304-097.0	Hexagonal head screw M8x70-8.8-A2E ISO	4.000	ST	0000000000	0000000000	
X-X	17	2.883-862.0	Spare part set chemistry	1.000	ST	0000000000	0000000000	
	100	2.884-214.0	SPARE PARTS KIT fuer Pumpensatz	1.000	ST	0000000000	0000000000	

17 Spare part set chemistry (2.883-862.0)

ET/VT (spare/wear parts)	Pos	Material #	Name	Qty.	Unit	from ser.nr.	up to ser.nr.
	10	5.110-714.0	Sleeve	1.000	ST	0000000000	0000000000
	20	5.332-258.0	Helical spring	1.000	ST	0000000000	0000000000
	30	5.380-014.0	Label	1.000	ST	0000000000	0000000000
	40	5.443-448.0	Nipple chemistry	1.000	ST	0000000000	0000000000
X-X	50	6.362-175.0	O-Ring seal 5,28x 1,78	1.000	ST	0000000000	0000000000
	60	6.362-451.0	O-Ring seal 8,0 x 1,0	1.000	ST	0000000000	0000000000
	70	7.401-909.0	Sphere 7 G40 -1.4401 DIN 5401	1.000	ST	0000000000	0000000000

**100 SPARE PARTS KIT fuer Pumpensatz (2.884-214.0)**

ET/VT (spare/wear parts)	Pos	Material #	Name	Qty.	Unit	from ser.nr.	up to ser.nr.
	10	4.030-045.0	Joining piece only for replacement	1.000	ST	0000000000	0000000000
	20	4.030-109.0	Throttle complete	1.000	ST	0000000000	0000000000
X-X	30	4.580-330.0	Suction valve complete	3.000	ST	0000000000	0000000000
	40	4.580-331.0	Valve complete	3.000	ST	0000000000	0000000000
	50	4.591-036.0	Excess-current complete	1.000	ST	0000000000	0000000000
	60	5.110-707.0	Sleeve	3.000	ST	0000000000	0000000000
X	70	5.115-720.0	Washer	3.000	ST	0000000000	0000000000
X-X	80	5.115-721.0	Washer	3.000	ST	0000000000	0000000000
X-X	90	6.362-384.0	O-Ring seal 9x1,5 - NBR 70	2.000	ST	0000000000	0000000000
	100	6.362-458.0	O-Ring seal 11,0x2,0-NBR 70	3.000	ST	0000000000	0000000000
	110	6.362-471.0	O-Ring seal 80,0 X 3,0 -NBR 70	1.000	ST	0000000000	0000000000
X-X	120	6.362-851.0	O-Ring seal 4 x 2 NBR 90	1.000	ST	0000000000	0000000000
X-X	130	6.365-393.0	Oil sealing 12x20x4/6	3.000	ST	0000000000	0000000000
X-X	140	6.365-394.0	Grooved ring 12x20x5,3/2,8	3.000	ST	0000000000	0000000000



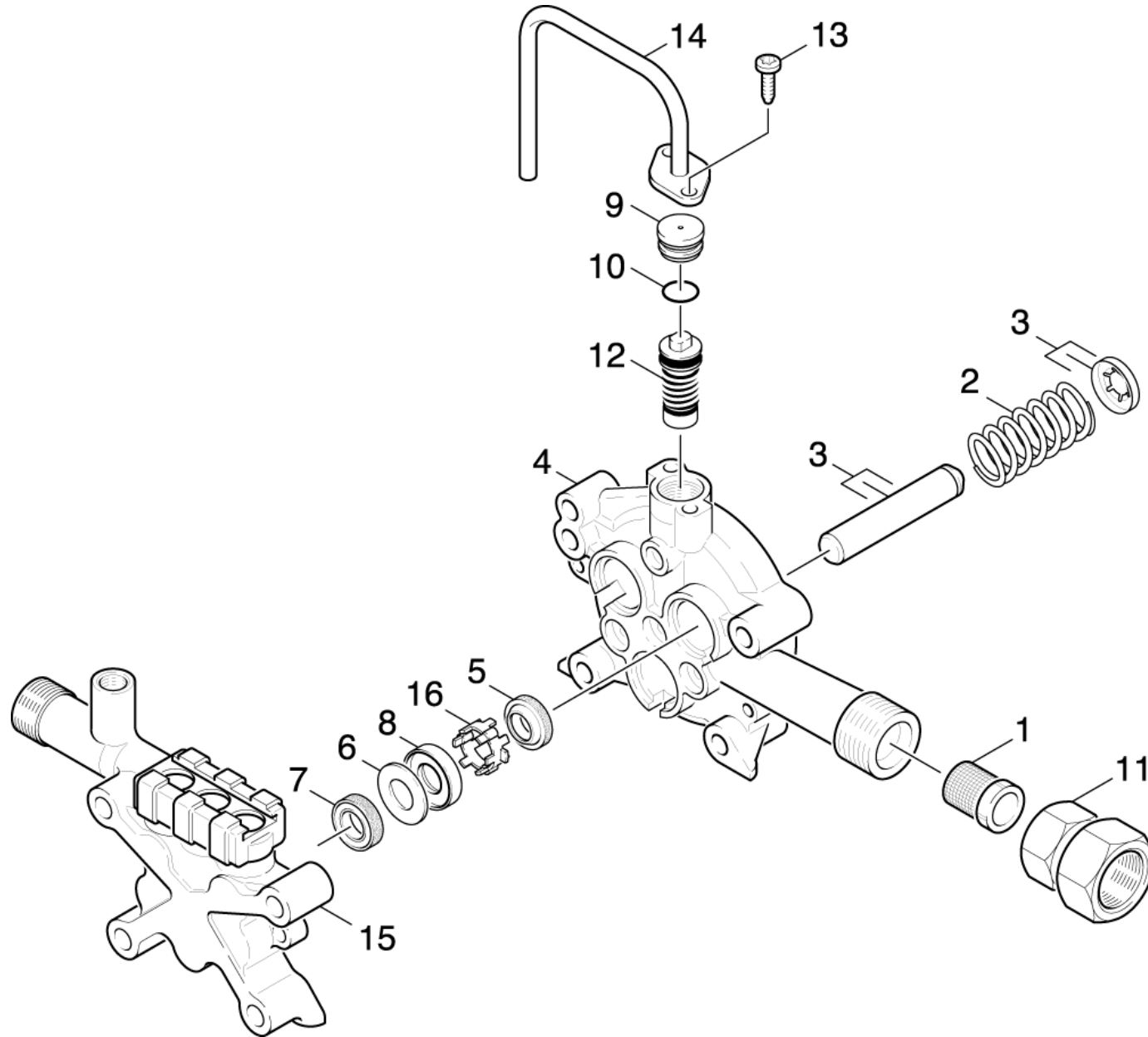

**22 Piston (0.107-408.0)**

ET/VT (spare/wear parts)	Pos	Material #	Name	Qty.	Unit	from ser.nr.	up to ser.nr.
X-X	1	6.414-252.0	Strainer	1.000	ST	0000000000	0000000000
X-X	2	5.332-391.0	Pressure spring	3.000	ST	0000000000	0000000000
	3	4.553-173.0	Piston complete	3.000	ST	0000000000	0000000000
	4	5.061-082.0	Piston guidance	1.000	ST	0000000000	0000000000
X-X	5	6.365-393.0	Oil sealing 12x20x4/6	3.000	ST	0000000000	0000000000
X-X	6	5.115-721.0	Washer	3.000	ST	0000000000	0000000000
X-X	7	6.365-394.0	Grooved ring 12x20x5,3/2,8	3.000	ST	0000000000	0000000000
X	8	5.115-720.0	Washer	3.000	ST	0000000000	0000000000
	9	5.132-118.0	Drain plug	1.000	ST	0000000000	0000000000
	10	6.363-174.0	O-Ring seal complete 12,42	1.000	ST	0000000000	0000000000
	11	9.154-009.0	Coupling element 3/4"	1.000	ST	0000000000	0000000000
	12	4.591-036.0	Excess-current complete	1.000	ST	0000000000	0000000000
	13	7.303-066.0	Screw M6x30 -St-R3R (In6Rd)	2.000	ST	0000000000	0000000000
	14	4.063-623.0	Cover horizontal	1.000	ST	0000000000	0000000000
	15	5.550-294.0	Cylinder head	1.000	ST	0000000000	0000000000
	16	5.110-707.0	Sleeve	3.000	ST	0000000000	0000000000

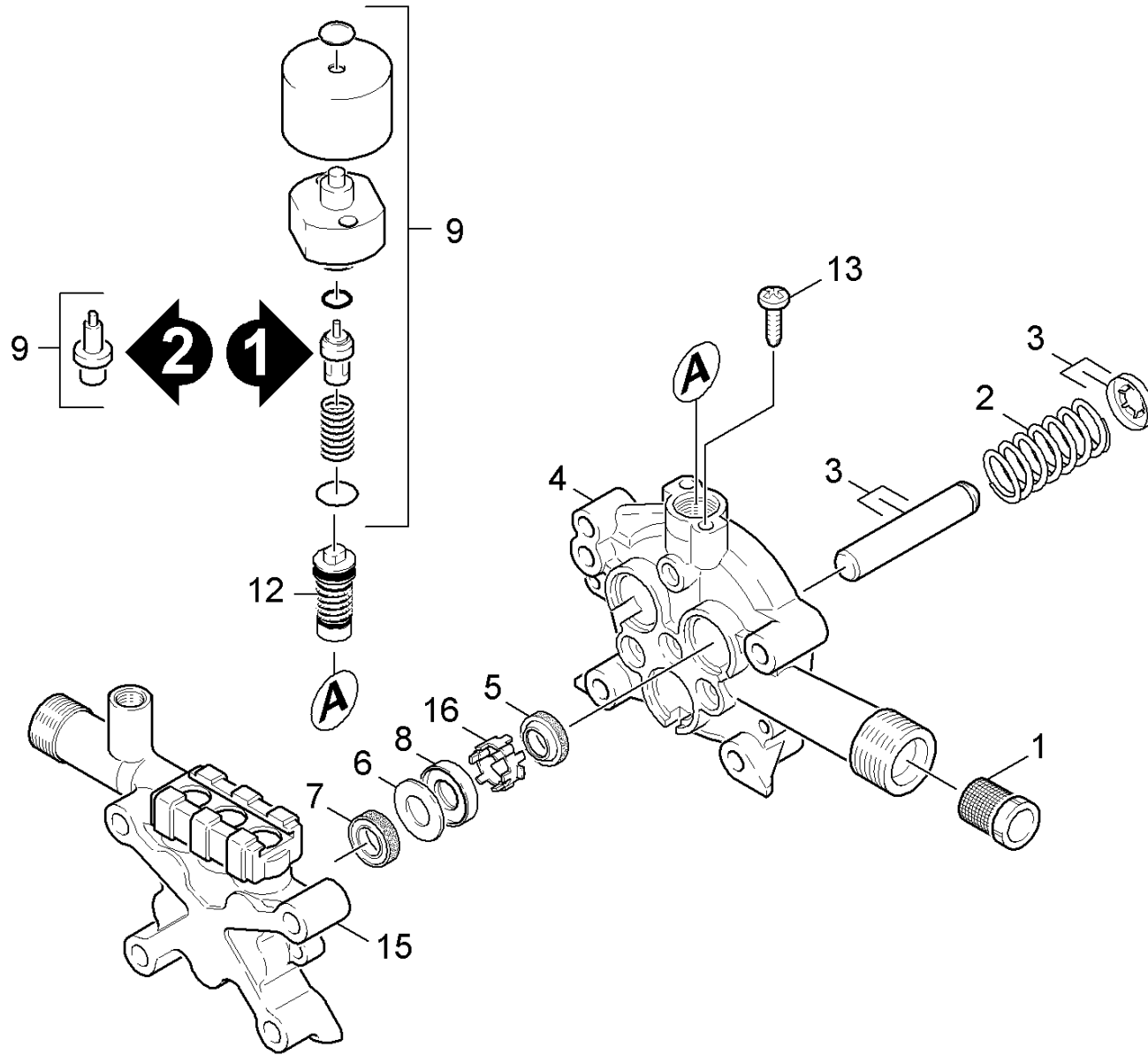

**23 Piston (0.107-473.0)**

ET/VT (spare/wear parts)	Pos	Material #	Name	Qty.	Unit	from ser.nr.	up to ser.nr.	var. information
X-X	1	6.414-252.0	Strainer	1.000	ST	0000000000	0000000000	
X-X	2	5.332-391.0	Pressure spring	3.000	ST	0000000000	0000000000	
	3	4.553-173.0	Piston complete	3.000	ST	0000000000	0000000000	
	4	5.061-082.0	Piston guidance	1.000	ST	0000000000	0000000000	
X-X	5	6.365-393.0	Oil sealing 12x20x4/6	3.000	ST	0000000000	0000000000	
X-X	6	5.115-721.0	Washer	3.000	ST	0000000000	0000000000	
X-X	7	6.365-394.0	Grooved ring 12x20x5,3/2,8	3.000	ST	0000000000	0000000000	
X	8	5.115-720.0	Washer	3.000	ST	0000000000	0000000000	
	9	4.580-344.0	Therموالve only for replacement	1.000	ST	0000000000	0000000000	VERSION 1
	9	4.580-359.0	Therموالve 60 GRD	1.000	ST	0000000000	0000000000	VERSION 2
	12	4.591-040.0	SPILL VALVE COMPLETE	1.000	ST	0000000000	0000000000	
	13	7.303-066.0	Screw M6x30 -St-R3R (In6Rd)	2.000	ST	0000000000	0000000000	
	15	5.550-294.0	Cylinder head	1.000	ST	0000000000	0000000000	
	16	5.110-707.0	Sleeve	3.000	ST	0000000000	0000000000	
	100	7.777-999.0	Stockpiling discontinued	1.000	ST	0000000000	0000000000	

**30 Motor (0.112-596.0)**

---

Pos	Material #	Name	Qty.	Unit	from ser.nr.	up to ser.nr.
31	0.125-049.0	Motor	1.000	ST	0000000000	0000000000
32	0.112-597.0	Motor	1.000	ST	0000000000	0000000000
34	0.112-611.0	Transmission	1.000	ST	0000000000	0000000000

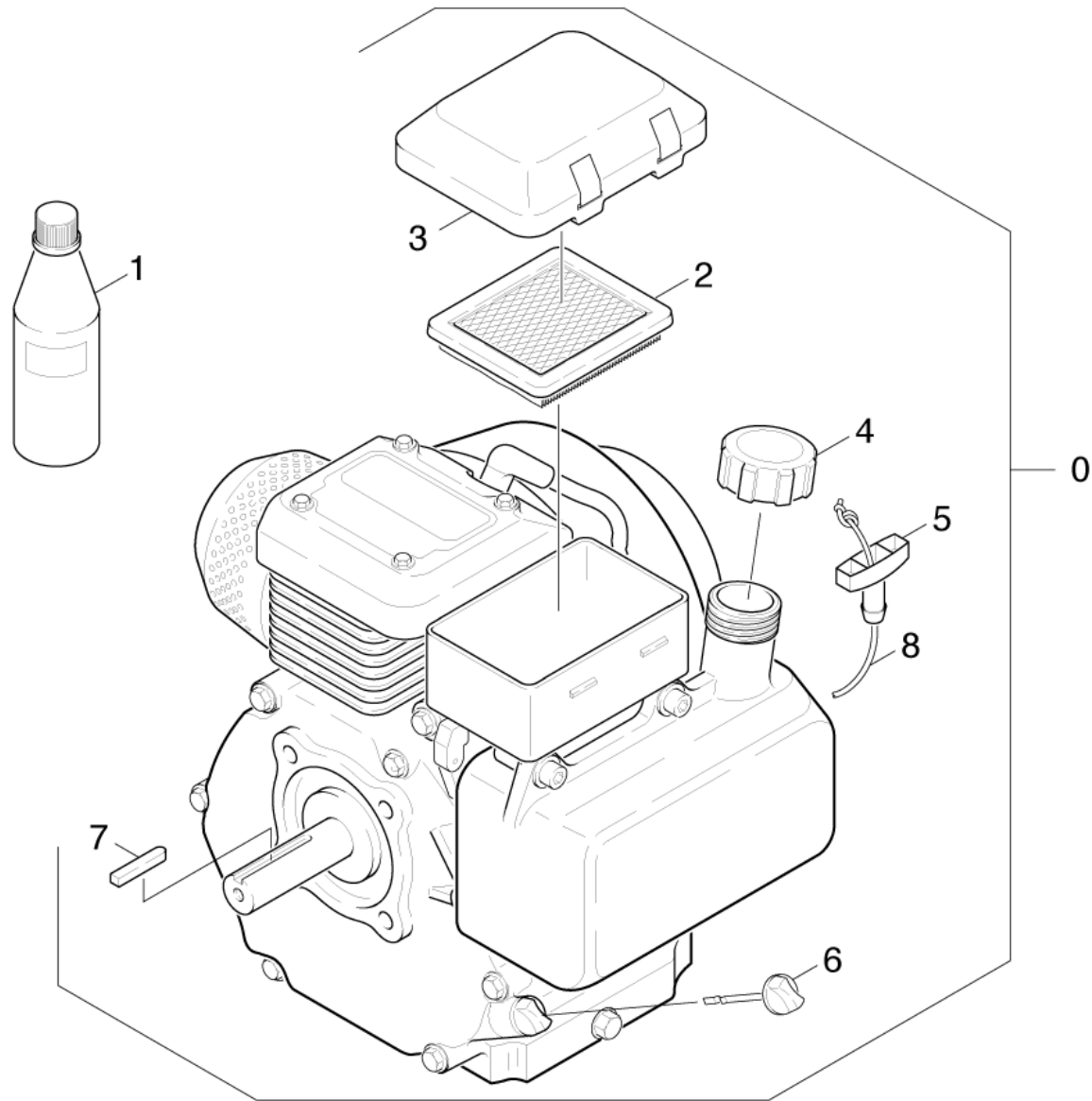

**31 Motor (0.125-049.0)**

ET/VT (spare/wear parts)	Pos	Material #	Name	Qty.	Unit	from ser.nr.	up to ser.nr.	Footnote text
	0	9.194-015.0	ENGINE -HONDA GC 160 QHA	1.000	ST	0000000000	0000000000	
Position text: / 1.194-110.0								
X-X	1	6.288-050.0	Engine oil 1L	1.000	ST	0000000000	0000000000	MOTOR 1,1L
	2	6.491-726.0	Air filter insert	1.000	ST	0000000000	0000000000	
	3	9.194-543.0	Cover	1.000	ST	0000000000	0000000000	
	4	6.491-723.0	Cap of a tank	1.000	ST	0000000000	0000000000	
	5	6.491-503.0	Handhold	1.000	ST	0000000000	0000000000	
	6	9.194-531.0	OIL DIP ROD	1.000	ST	0000000000	0000000000	
	7	9.194-883.0	Shaft key 3/16"SQx1.5"	1.000	ST	0000000000	0000000000	
	8	6.491-546.0	Pull cord	1.000	ST	0000000000	0000000000	

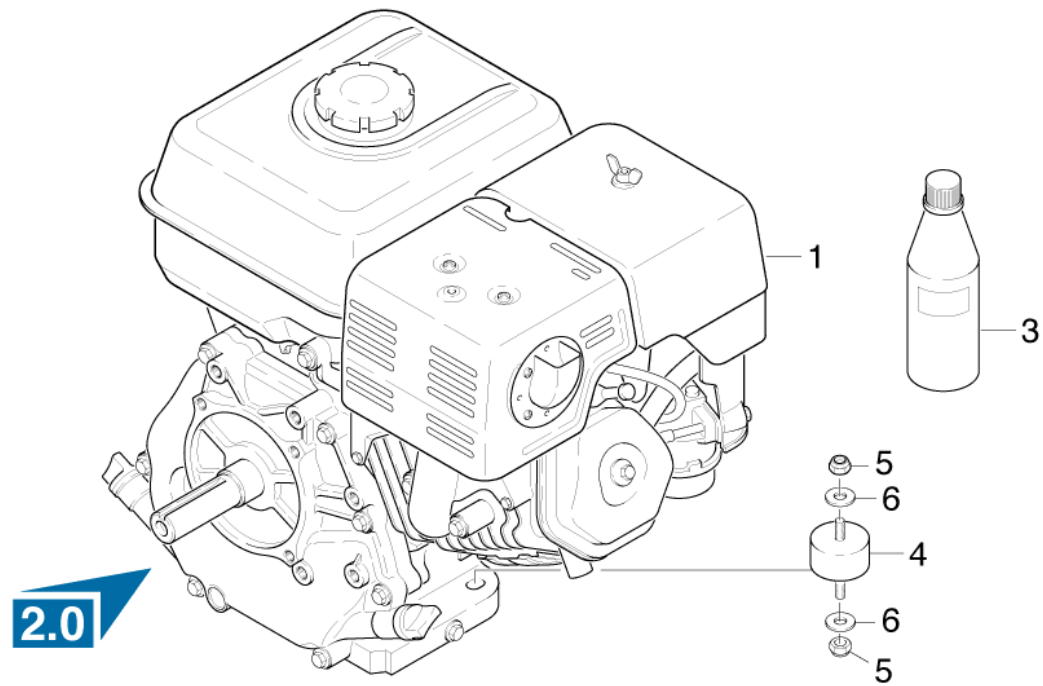



**32 Motor (0.112-597.0)**

ET/VT (spare/wear parts)	Pos	Material #	Name	Qty.	Unit	from ser.nr.	up to ser.nr.
	1	7.777-999.0	Stockpiling discontinued	1.000	ST	0000000000	0000000000
Position text: / 1.194-109.0							
X-X	3	6.288-050.0	Engine oil 1L	1.000	ST	0000000000	0000000000
	4	9.183-403.0	RUBBER DAMPENER DIA.35x16	4.000	ST	0000000000	0000000000
	5	9.197-002.0	5/16-18 NE NYLON INSERT L/N ZC 5UM	8.000	ST	0000000000	0000000000
X-X	6	7.312-004.0	Washer 8 -200HV-A3E ISO 7090	8.000	ST	0000000000	0000000000

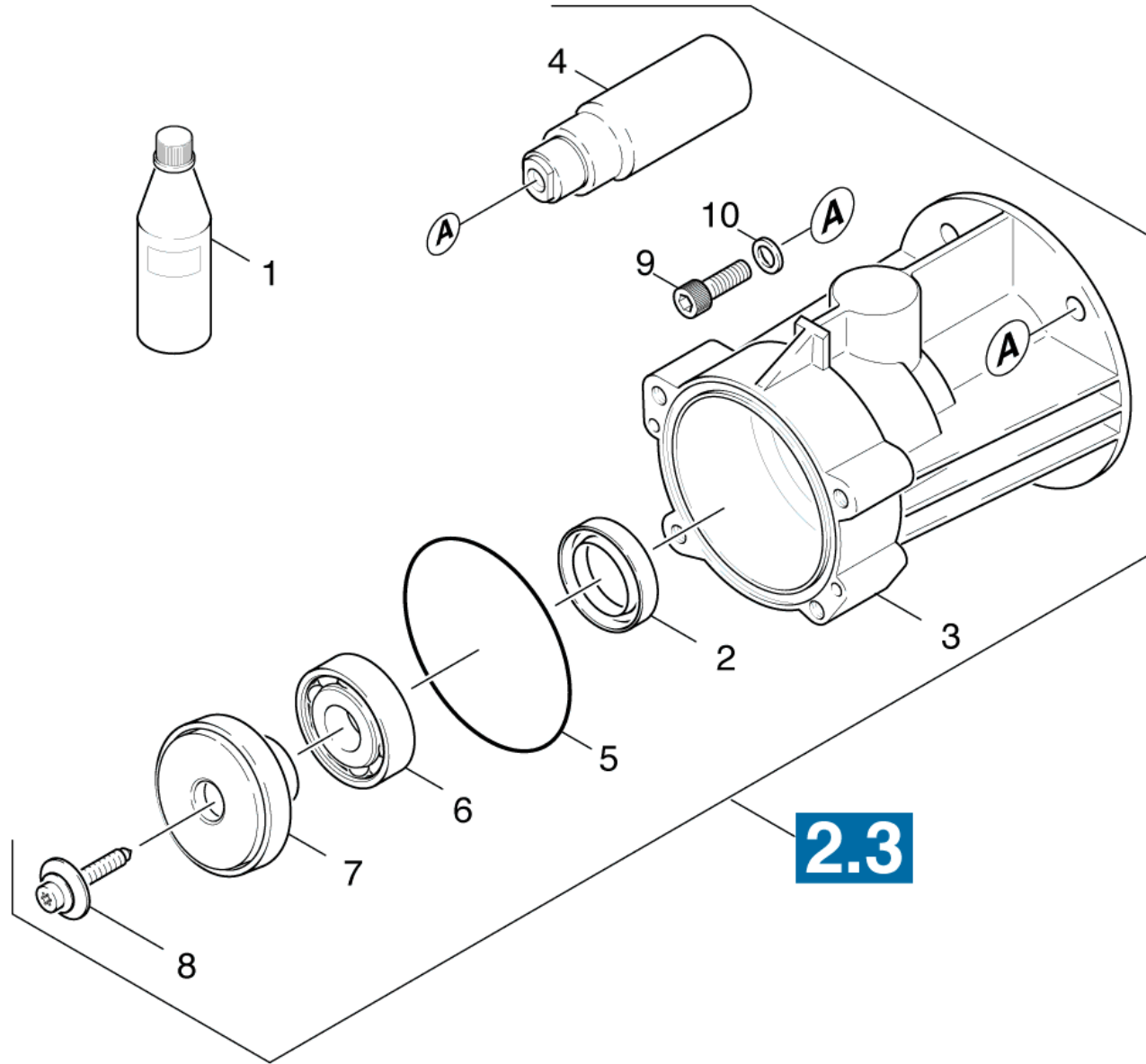

**34 Transmission (0.112-611.0)**

ET/VT (spare/wear parts)	Pos	Material #	Name	Qty.	Unit	from ser.nr.	up to ser.nr.
X-X	1	6.288-050.0	Engine oil 1L	1.000	ST	0000000000	0000000000
	2	7.367-018.0	Radial shaft seal ring A26x37x7 -NBR DI	1.000	ST	0000000000	0000000000
	3	5.093-106.0	Housing horizontal	1.000	ST	0000000000	0000000000
	4	5.471-088.0	Coupling element horizontal	1.000	ST	0000000000	0000000000
	5	6.362-471.0	O-Ring seal 80,0 X 3,0 -NBR 70	1.000	ST	0000000000	0000000000
	6	7.401-155.0	Ball bearing 6304-WAELZLAGERST DIN 625	1.000	ST	0000000000	0000000000
	7	6.401-289.0	Wobble plate	1.000	ST	0000000000	0000000000
	8	6.304-048.0	Cylinder head screw M6x19	1.000	ST	0000000000	0000000000
	9	6.965-007.0	5/16-24X1 GR 5 SHCS THRU HARDENED ZC	4.000	ST	0000000000	0000000000
	10	5.115-656.0	Washer	4.000	ST	0000000000	0000000000

40 Accessories (0.147-896.0)

---

Pos	Material #	Name	Qty.	Unit	from ser.nr.	up to ser.nr.	var. information
41	0.148-122.0	Hand trigger gun	1.000	ST	0000000000	0000000000	
42	0.146-720.0	Triple jet nozzle	1.000	ST	0000000000	0000000000	VERSION 1
43	0.103-784.0	Triple jet nozzle	1.000	ST			VERSION 2

---

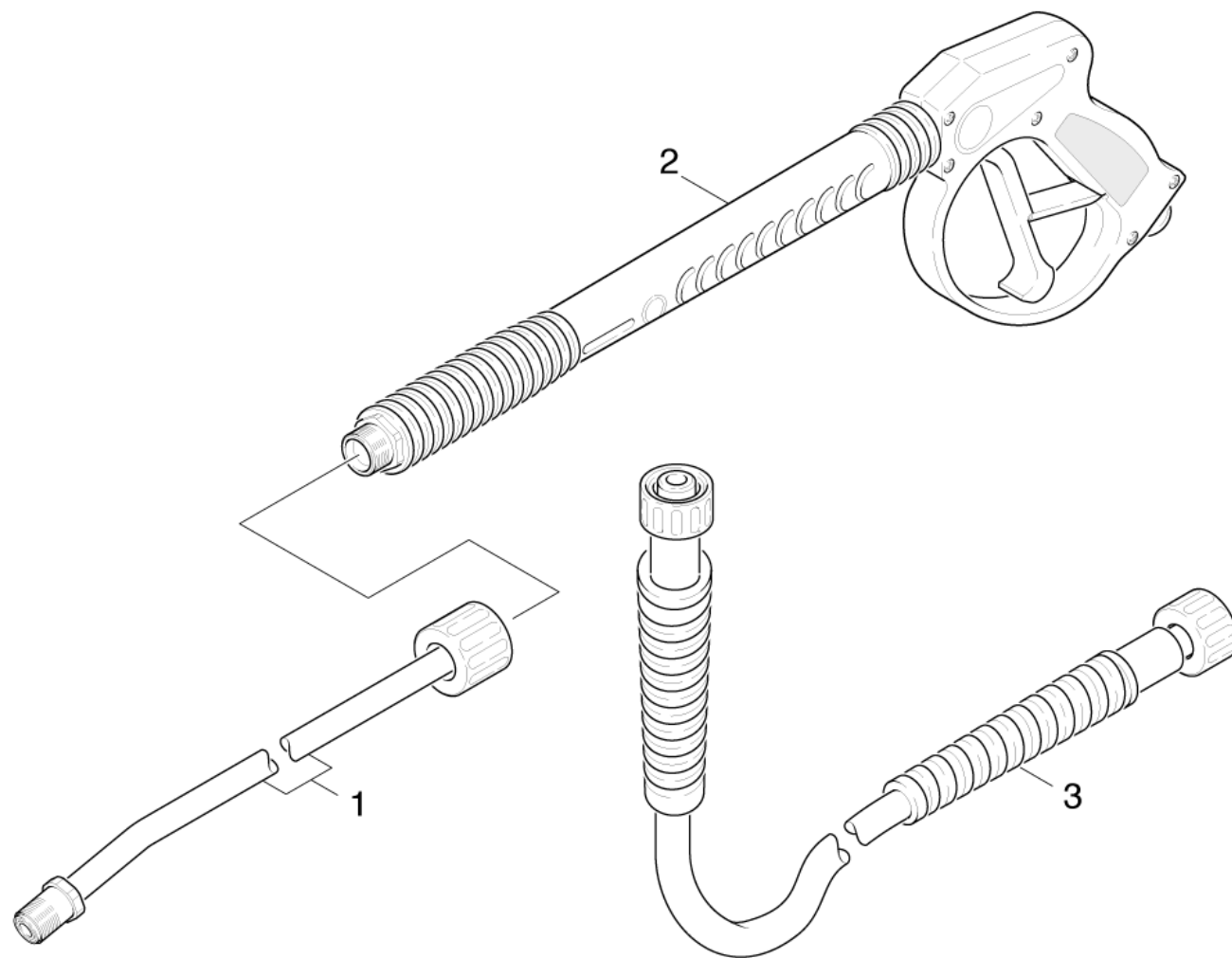

**41 Hand trigger gun (0.148-122.0)**

Pos	Material #	Name	Qty.	Unit	from ser.nr.	up to ser.nr.
1	9.112-504.0	SPRAY LANCE	1.000	ST	0000000000	0000000000
2	9.112-009.0	TRIGGER GUN SK2 M22x1.5 MALE/MALE	1.000	ST	0000000000	0000000000
3	9.162-321.0	HP HOSE DN6/25'/3000/KA/BLK/PLSTC	1.000	ST	0000000000	0000000000
Position text: / 1.194-110.0						
3	7.777-999.0	Stockpiling discontinued	1.000	ST	0000000000	0000000000

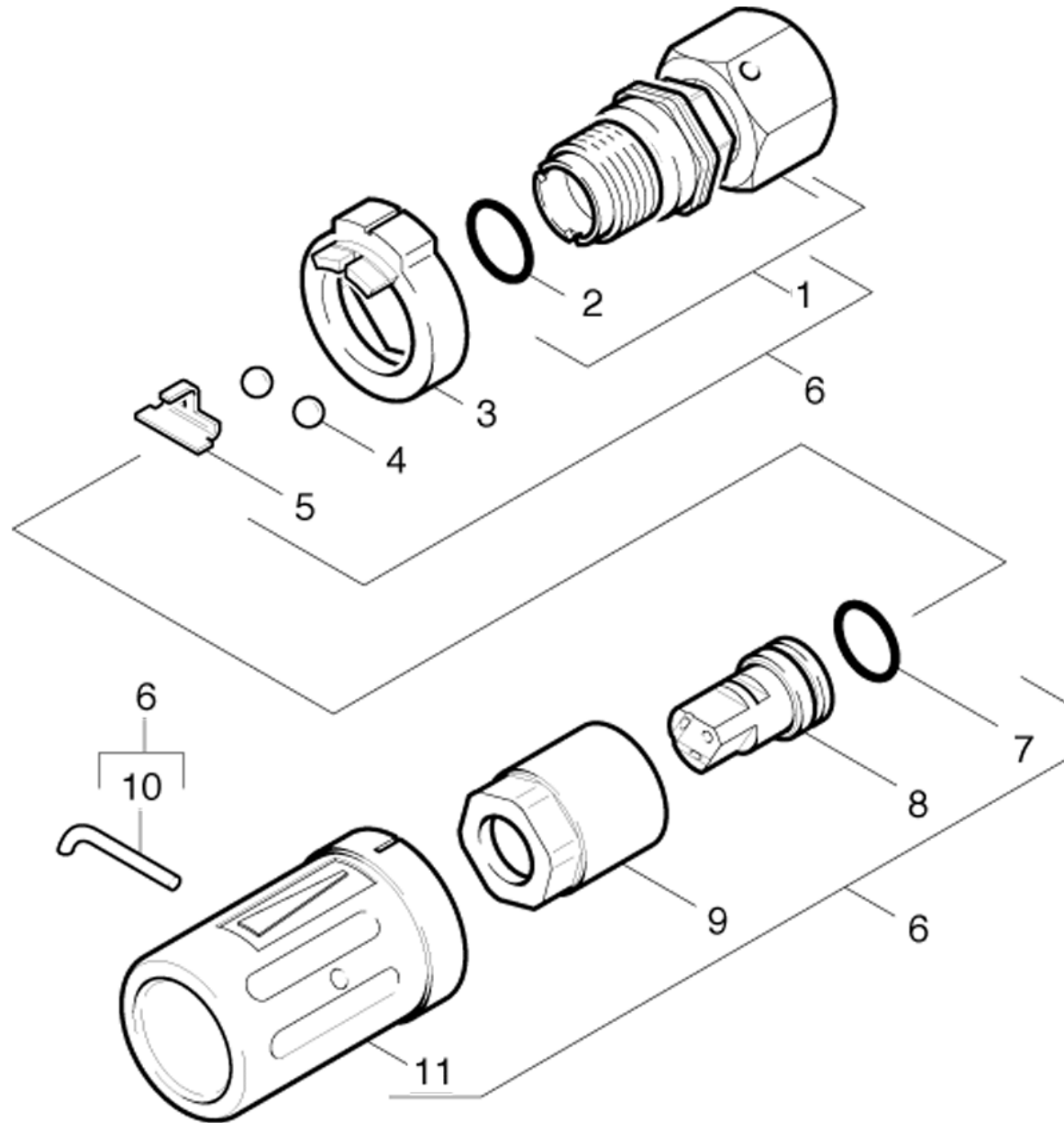

**42 Triple jet nozzle (0.146-720.0)**

ET/VT (spare/wear parts)	Pos	Material #	Name	Qty.	Unit	from ser.nr.	up to ser.nr.
	1	4.402-042.0	Screw union	1.000	ST	0000000000	0000000000
	2	6.362-460.0	O-Ring seal 14,0 X 2,5-NBR 70	1.000	ST	0000000000	0000000000
	3	5.030-528.0	Moulded part	1.000	ST	0000000000	0000000000
	4	7.401-902.0	Sphere 5 G20 -1.4034 DIN 5401	2.000	ST	0000000000	0000000000
	5	5.042-405.0	Holder	1.000	ST	0000000000	0000000000
	6	7.777-999.0	Stockpiling discontinued	1.000	ST	0000000000	0000000000
X-X	7	6.362-480.0	O-Ring seal 12,42x 1,78	1.000	ST	0000000000	0000000000
	8	7.777-999.0	Stockpiling discontinued	1.000	ST	0000000000	0000000000
	9	5.311-117.0	Hexagon nut	1.000	ST	0000000000	0000000000
	10	5.037-059.0	Hook	1.000	ST	0000000000	0000000000
	11	5.394-269.0	Protection part	1.000	ST	0000000000	0000000000



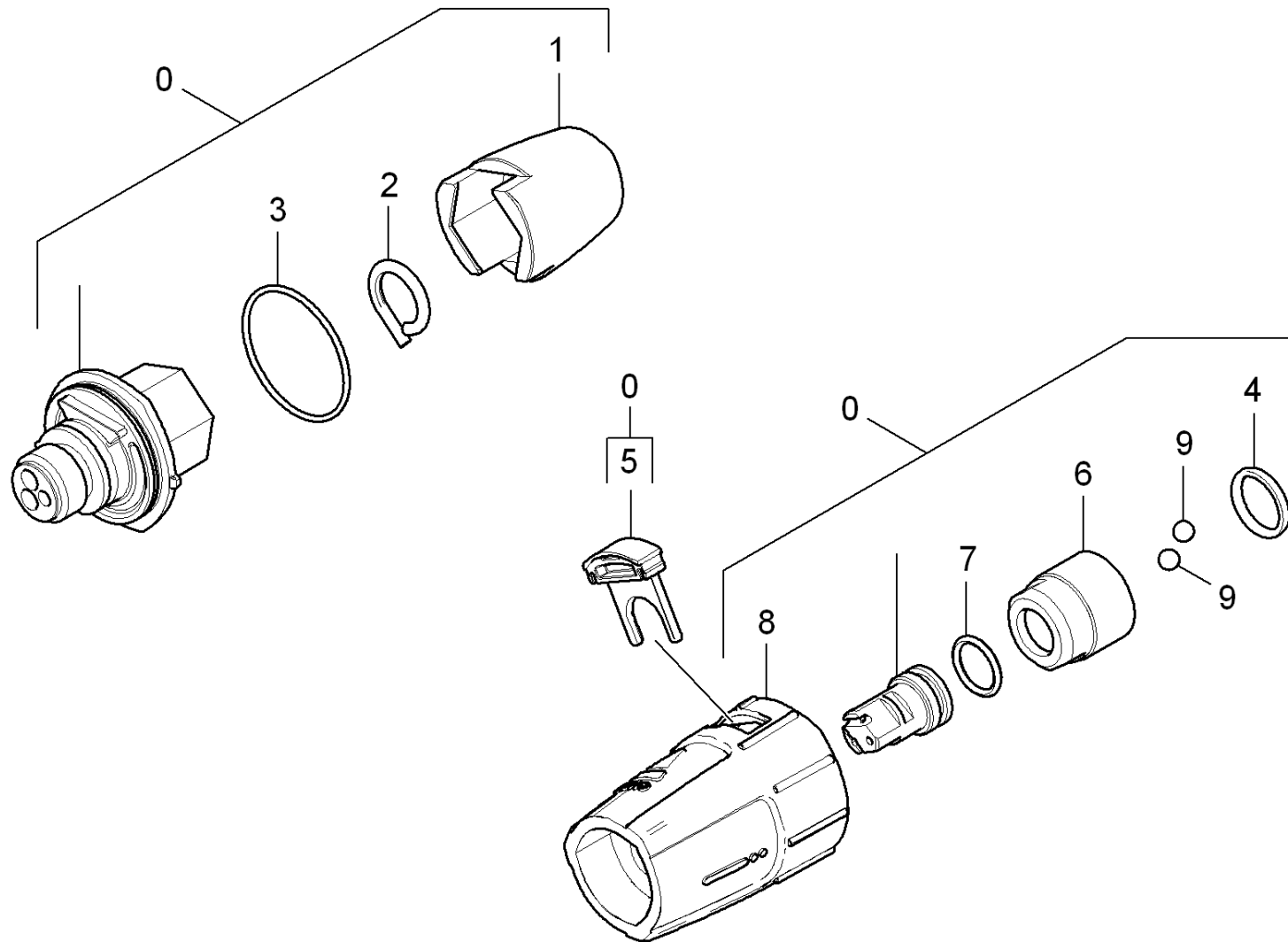

**43 Triple jet nozzle (0.103-784.0)**

ET/VT (spare/wear parts)	Pos	Material #	Name	Qty.	Unit
	0	4.767-146.0	Triple jet nozzle replacement 033	1.000	ST
	1	5.394-530.0	Protection part complete	1.000	ST
	2	6.343-150.0	Pin 03	1.000	ST
	3	6.362-409.0	O-Ring seal 32,0 X 1,5	1.000	ST
	4	6.362-460.0	O-Ring seal 14,0 X 2,5-NBR 70	1.000	ST
	5	5.321-884.0	Clamp	1.000	ST
	6	5.311-225.0	Nut	1.000	ST
X-X	7	6.362-480.0	O-Ring seal 12,42x 1,78	1.000	ST
	8	5.394-859.0	Protection part	1.000	ST
	9	7.401-902.0	Sphere 5 G20 -1.4034 DIN 5401	2.000	ST