

Spare parts list
(5.970-063.0) Spare parts list K 2301 *

DE HINWEISE

Weitere Sprachen:

Diese Ersatzteilliste ist in weiteren Sprachen erhältlich. Sie erhalten diese unter www.kaercher.com im Bereich Service.
Die Schreibweise der Teilenummer, z.B. 75456380, entspricht der Teilenummer 7.545-638.0.

Mengenangaben:

Die Mengenangaben in der Ersatzteilliste entsprechen den in der Baugruppe verbauten Stückzahlen der Bauteile.

Meterware:

Ersatzteile welche als Meterware geliefert werden sind auf Einbaulänge selbst zu kürzen. Die Stückzahlen sind als Mindestbestellmenge =1m angegeben und müssen je nach Bedarf auf weitere volle Meterzahlen erhöht werden.

Versionen/ Werknummern:

Sind Versionen oder Werknummern in der Ersatzteilliste angegeben, ist anhand dieser vor Bestellung zu prüfen, welches Bauteil für ihr Gerät verwendet werden muss.

Lackierte Teile:

Bei Bestellungen von lackierten Teilen welche in der Ersatzteilliste nicht in verschiedenen Farben ausgewiesen sind, ist zusätzlich die Farbnummer oder Farbe mit anzugeben.

Technische Änderungen:

Technische Änderungen sowie das Recht der ausschließlichen Auswertung unseres geistigen Eigentums behalten wir uns vor.

EN INSTRUCTIONS

Other languages:

This list of spare parts is also available in other languages. You can get this list from www.kaercher.com in the Service division.
The designation of the part number e.g. 75456380 is equal to 7.545-638.0.

Quantity details:

The quantity details in the spare parts list correspond to the number of pieces of the component installed in the assembly group.

Piece goods:

Spare parts that are sold as piece goods are to be cut to the desired length. The quantities have been indicated as minimum order quantity =1m and must be rounded off to the full meter figure depending on your requirements.

Version/ Plant numbers:

If version or plant numbers are mentioned in the spare parts list, then use the same to check before ordering which spare part needs to be used for your appliance.

Painted parts:

While ordering painted parts that are not mentioned in the spare parts list in their colour variations, please mention the colour number or the colour you require.

Technical changes:

We reserve the right to make technical changes as well as the right to exclusive use of our intellectual property.

FR REMARQUES

Autres langues:

Cette liste de pièces de rechange est disponible en autres langues. Cela est disponible sous www.kaercher.com dans le menu Service.
La désignation du numéro de pièce, par ex. 75456380, correspond au numéro de pièce 7.545-638.0.

Indications de quantité:

Les indications de quantité dans la liste de pièces de rechange correspondre aux nombres de pièces des composant utilisées dans la construction.

Matériel au mètre:

Les pièces de rechange qui sont livrées au mètre doivent être raccourcies à longueur souhaitée par l'acheteur même. Les nombres des pièces sont indiquées en quantité de commande minimale = 1m et doivent être augmentés selon le besoin à une chiffre de mètre complète.

Versions/ Numéros d'usine:

Lorsqu'il sont indiquées des versions ou des numéros d'usine dans la liste de pièces de rechange, vous devez vérifier que composant doit être utilisé pour votre appareil.

Pièces laquées:

Pour commander des pièces laquées, où les différentes couleurs ne sont pas indiquées dans la liste des pièces de rechange, vous devez indiquer en plus le numéro de la couleur ou seulement la couleur.

Modifications techniques:

Nous nous réservons la possibilité des modifications techniques ainsi le droit d'exploitation exclusive de notre propriété intellectuelle.

IT AVVERTENZE

Altre lingue:

Il presente elenco di parti di ricambio è disponibile sul nostro sito Web anche in altre lingue: sotto www.kaercher.com alla voce "Service".

L'indicazione del codice pezzo, ad es. 75456380, corrisponde al codice pezzo 7.545-638.0

Indicazioni di quantità:

Le indicazioni di quantità riportate dall'elenco "parti di ricambio" corrispondono al numero delle singole componenti contenute nella rispettiva unità.

Merce a metro:

Le parti di ricambio fornite come "merce a metro" devono venire in seguito accorciate alla lunghezza necessaria per il montaggio. La quantità unitaria è indicata come "quantità minima di ordinazione = 1m" e deve all'occorrenza venire moltiplicata per il numero intero di metri necessari.

Versioni / Numeri di fabbricazione:

Quando l'elenco "parti di ricambio" riporta diverse versioni o numeri di fabbricazione, confrontare la versione o il numero di fabbricazione del ricambio desiderato con quelle/i presenti nell'elenco e indicarla/o al momento dell'ordinazione.

Parti di ricambio verniciate:

Nel caso di ricambi verniciati, se l'elenco parti di ricambio non ne riporta espressamente i diversi colori, al momento dell'ordinazione è necessario indicare anche il colore o il numero del colore desiderato.

Modifiche tecniche:

Ci riserviamo il diritto di apportare modifiche tecniche così come il diritto di utilizzo esclusivo della nostra proprietà intellettuale.

ES INDICACIONES

Otros idiomas:

La lista de piezas de repuesto se puede adquirir en otros idiomas. La puede adquirir en www.kaercher.com en el área de servicios.

La notación de los números de las piezas, p.ej. 75456380 corresponde al número de pieza 7.545-638.0.

Cantidades:

Las indicaciones de cantidades de la lista de piezas de repuesto corresponden al número de piezas montadas en el componente.

Mercancía por metros:

Las piezas de repuesto que se suministran por metros se pueden cortar al largo deseado. La unidad mínima de pedido es de = 1 m y el número de metros completos se puede aumentar según necesidad.

Versiones/números de fábrica:

Si se indica la versión o número de fábrica en la lista de piezas de repuesto, se debe comprobar en ella la pieza a usar para su aparato antes de realizar el pedido.

Piezas lacadas:

Al realizar pedidos de piezas lacadas que no estén indicadas en los diferentes colores en la lista de piezas de repuesto, se debe indicar también la referencia del color o el color.

Modificaciones técnicas:

Reservados los derechos de realizar modificaciones técnicas y aprovechar nuestra propiedad intelectual.

PL WSKAZÓWKI

Pozostałe języki:

Ta lista części zamiennych jest dostępna w także w innych językach. Mogą ją Państwo pobrać ze strony www.kaercher.com w dziale Serwis.

Sposób zapisywania numeru części, np. 75456380, odpowiada numerowi części 7.545-638.0.

Dane ilości:

Dane ilości podane w liście części zamiennych odpowiadają liczbie sztuk podzespołów tworzących dany moduł.

Towar sprzedawany na metry:

Części zamienne dostarczane jako towar sprzedawany na metry po zamontowaniu należy samodzielnie skrócić do potrzebnej długości. Liczba sztuk podana jest jako minimalna ilość zamówienia = 1m i w zależności od potrzeb zwiększa się ją o kolejne pełne metry.

Wersje/ Numer zakładu:

Jeżeli w liście części zamiennych podane są wersje lub numery zakładu, przed zamówieniem na ich podstawie należy sprawdzić, który podzespół stosuje się w Państwa urządzeniu.

Części lakierowane:

W przypadku zamówień części lakierowanych, które w liście części zamiennych nie podano w wielu kolorach, należy dodatkowo zaznaczyć nr koloru lub kolor.

Zmiany techniczne:

Zastrzegamy sobie prawo do zmian technicznych oraz wyłącznego wykorzystywania naszej własności intelektualnej.

RU УКАЗАНИЯ:

Другие языки:

Данный список запасных частей также доступен на других языках. Вы найдете его на сайте www.kaercher.com в разделе Service
Маркировка номера детали, например, 75456380, соответствует номеру детали 7.545-638.0.

Указание количества:

Количественные данные в списке запасных частей соответствуют числу компонентов, входящих в состав узлов.

Товар, продаваемый на метры:

Запасные части, продающиеся на метры, необходимо обрезать до нужной длины. Число изделий указано в виде минимального объема заказа = 1м и их количество можно округлить до требуемого по мере необходимости.

Варианты исполнения/заводские номера:

Если варианты исполнения или заводские номера указаны в списке запасных частей, то перед заказом необходимо проверить, какая деталь подходит для вашего устройства.

Лакированные детали:

При заказе лакированных деталей, варианты расцветки которых не указаны в списке запасных частей, необходимо дополнительно указать номер цвета или необходимый для вас цвет.

Технические изменения:

Мы оставляем за собой право на технические изменения, а также право на исключительное использование нашей интеллектуальной собственности.

Table of contents

Spare parts list K 2301 * (5.970-063.0)	6
10 Individual parts (0.102-953.0).....	7
20 Pump set (0.108-300.0).....	9
21 Cylinder head (0.108-301.0).....	10
22 Piston (0.108-302.0).....	12
30 Motor (0.112-792.0).....	14
31 Motor (0.112-793.0).....	15
32 Transmission (0.112-794.0).....	17
40 Accessories (0.148-498.0).....	19
41 Hand trigger gun (0.148-499.0).....	20
42 Hand trigger gun (0.148-607.0).....	22
43 Jet pipe (0.148-500.0).....	24

Spare parts list K 2301 * (5.970-063.0)

Pos	Name	Qty.	Unit	from ser.nr.	up to ser.nr.
10	Individual parts	1.000	ST	0000000000	0000000000
20	Pump set	1.000	ST	0000000000	0000000000
30	Motor	1.000	ST	0000000000	0000000000
40	Accessories	1.000	ST	0000000000	0000000000

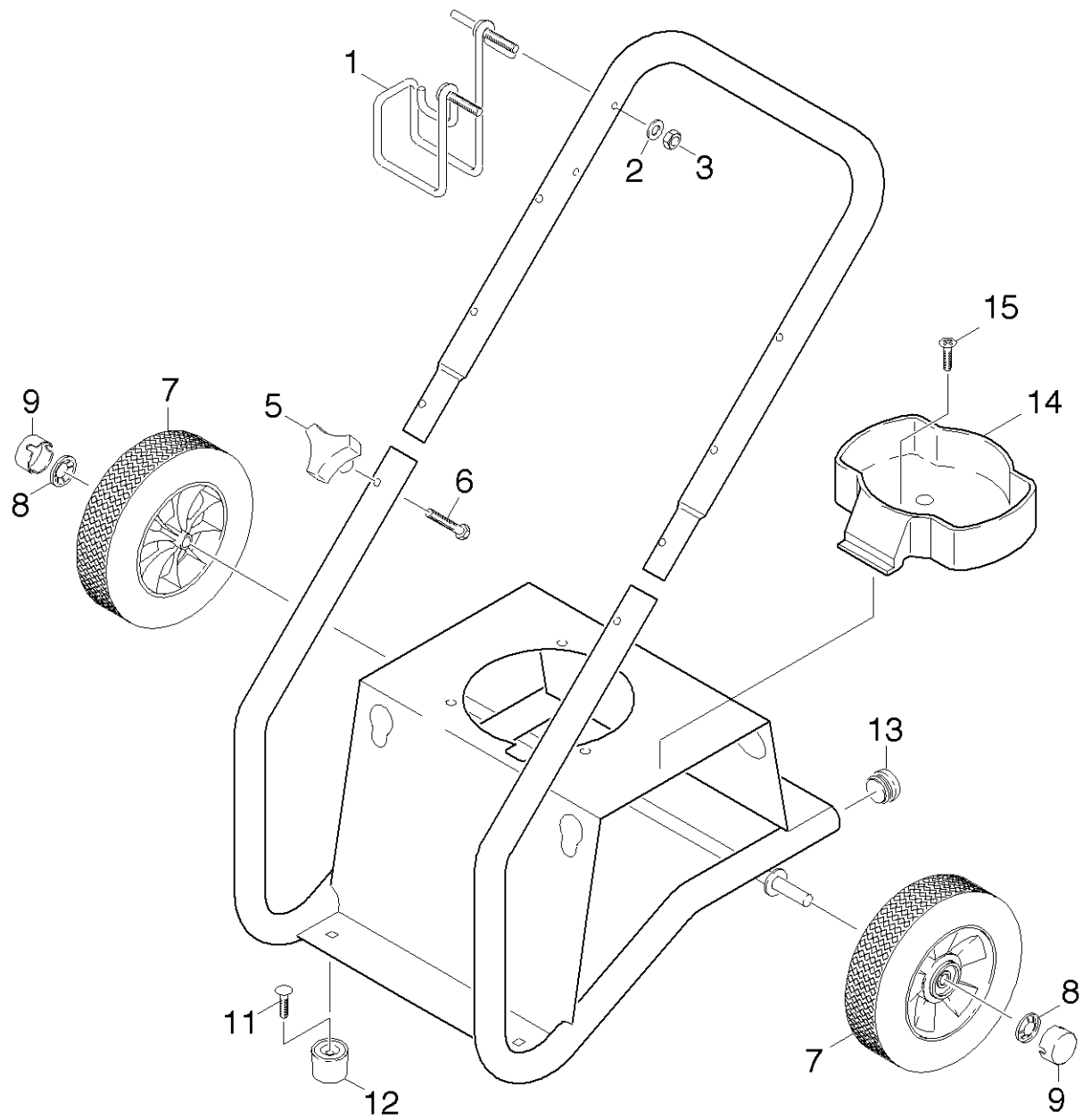

10 Individual parts (0.102-953.0)

Pos	Material #	Name	Qty.	Unit	from ser.nr.	up to ser.nr.
1	9.142-009.0	HANGER WELD ASSY 45DEG RIGHT (SOLO)	1.000	ST	0000000000	0000000000
2	9.198-003.0	5/16 INTERNAL L/W .332 ID X .620 OD ZINC	2.000	ST	0000000000	0000000000
3	5.310-105.0	5/16"-18 FINISHED HEX NUT ZINC	2.000	ST	0000000000	0000000000
5	9.182-353.0	KNOB 1/4"-20,3PT. STAR	2.000	ST	0000000000	0000000000
6	9.196-307.0	1/4-20 x 1-1/2 GR 2 HEX BOLT ZINC	2.000	ST	0000000000	0000000000
7	9.189-004.0	Wheel D 198	2.000	ST	0000000000	0000000000
8	6.343-181.0	Quick-fastener -D1/2"	2.000	ST	0000000000	0000000000
9	6.435-221.0	Wheel cap	2.000	ST	0000000000	0000000000
11	9.196-308.0	5/16-18 X 1/2 CARRIAGE BOLT A307 BLK	2.000	ST	0000000000	0000000000
12	9.183-405.0	RUBBER DAMPENER 5/16"-18FEMALE 2001	2.000	ST	0000000000	0000000000
13	9.183-001.0	BLACK,PLUG PLASTIC	2.000	ST	0000000000	0000000000
14	9.134-007.0	DETERGENT TRAY	1.000	ST	0000000000	0000000000
15	9.196-028.0	10-24 X 1/2 PH FLAT U/C T-F CASE HARD	1.000	ST	0000000000	0000000000

20 Pump set (0.108-300.0)

Pos	Name	Qty.	Unit	from ser.nr.	up to ser.nr.
21	Cylinder head	1.000	ST	0000000000	0000000000
22	Piston	1.000	ST	0000000000	0000000000

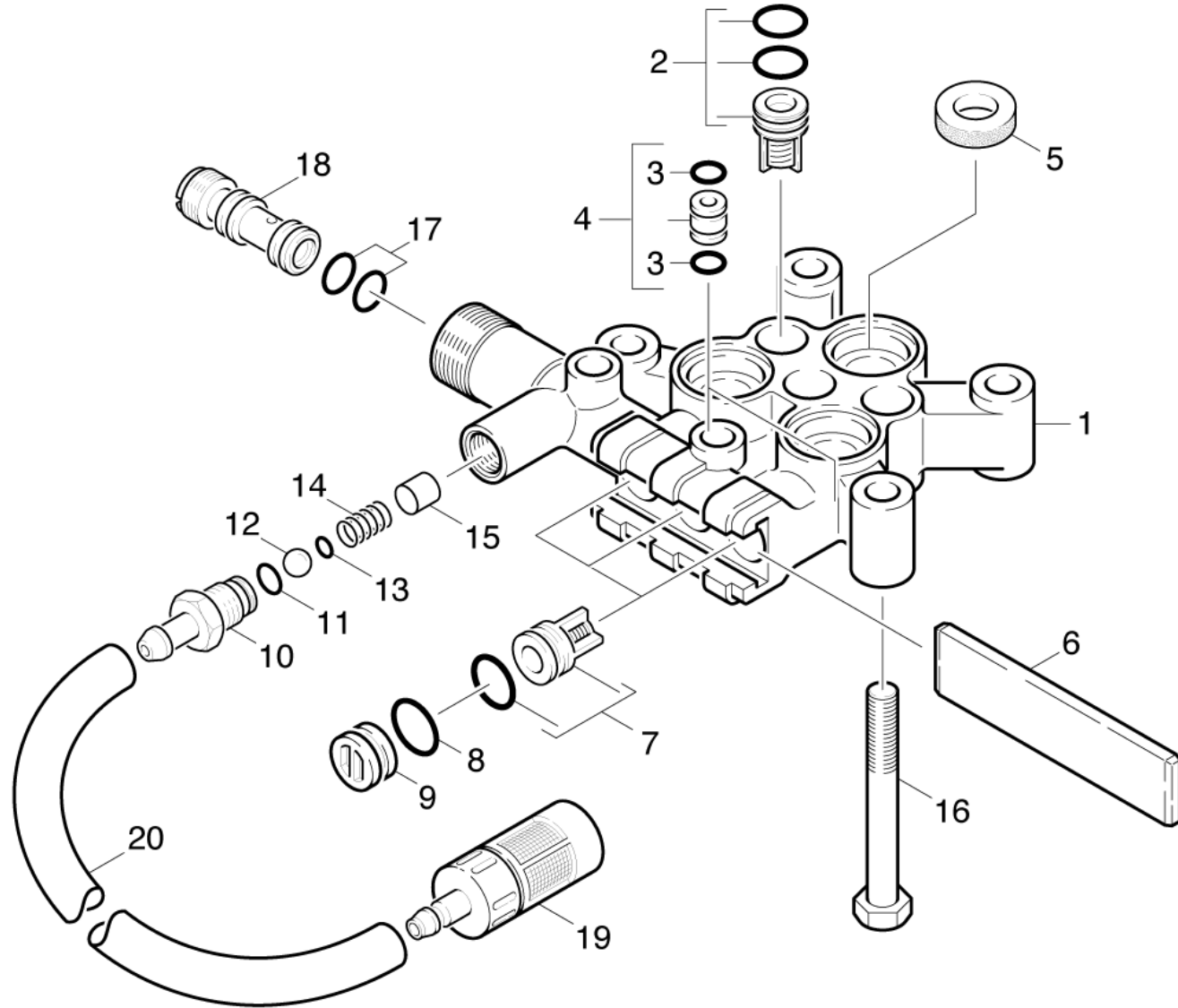

21 Cylinder head (0.108-301.0)

ET/VT (spare/wear parts)	Pos	Material #	Name	Qty.	Unit	from ser.nr.	up to ser.nr.	Footnote text
	1	5.550-294.0	Cylinder head	1.000	ST	0000000000	0000000000	
X-X	2	4.580-330.0	Suction valve complete	3.000	ST	0000000000	0000000000	
	3	6.362-176.0	O-Ring seal 6,07x1,78	4.000	ST	0000000000	0000000000	
	4	4.030-125.0	Joining piece only for replacement	2.000	ST	0000000000	0000000000	
X-X	5	6.365-394.0	Grooved ring 12x20x5,3/2,8	3.000	ST	0000000000	0000000000	
	6	5.003-062.0	Plate	1.000	ST	0000000000	0000000000	
	7	2.884-880.0	Valve (3 Stueck)	1.000	ST	0000000000	0000000000	
	8	6.363-273.0	O-Ring seal 11,0 x 2,0	3.000	ST	0000000000	0000000000	
X-X	9	4.132-007.0	Drain plug only for replacement	3.000	ST	0000000000	0000000000	
	10	5.443-448.0	Nipple chemistry	1.000	ST	0000000000	0000000000	
	11	6.362-451.0	O-Ring seal 8,0 x 1,0	1.000	ST	0000000000	0000000000	
	12	7.401-908.0	Sphere 7 G300 -1.4301 DIN 5401	1.000	ST	0000000000	0000000000	
X-X	13	6.362-175.0	O-Ring seal 5,28x 1,78	1.000	ST	0000000000	0000000000	
	14	5.332-258.0	Helical spring	1.000	ST	0000000000	0000000000	
	15	5.110-714.0	Sleeve	1.000	ST	0000000000	0000000000	
	16	7.304-408.0	Hexagonal head screw M 8x80-8.8-A2E ISO	4.000	ST	0000000000	0000000000	
X-X	17	6.362-384.0	O-Ring seal 9x1,5 - NBR 70	2.000	ST	0000000000	0000000000	
	18	4.769-040.0	Nozzle insert	1.000	ST	0000000000	0000000000	
	19	4.862-032.0	Filter chemistry regulation	1.000	ST	0000000000	0000000000	
	20	6.388-216.0	Hose DN 5	1.000	M	0000000000	0000000000	TO ORDER AS CUT GOODS

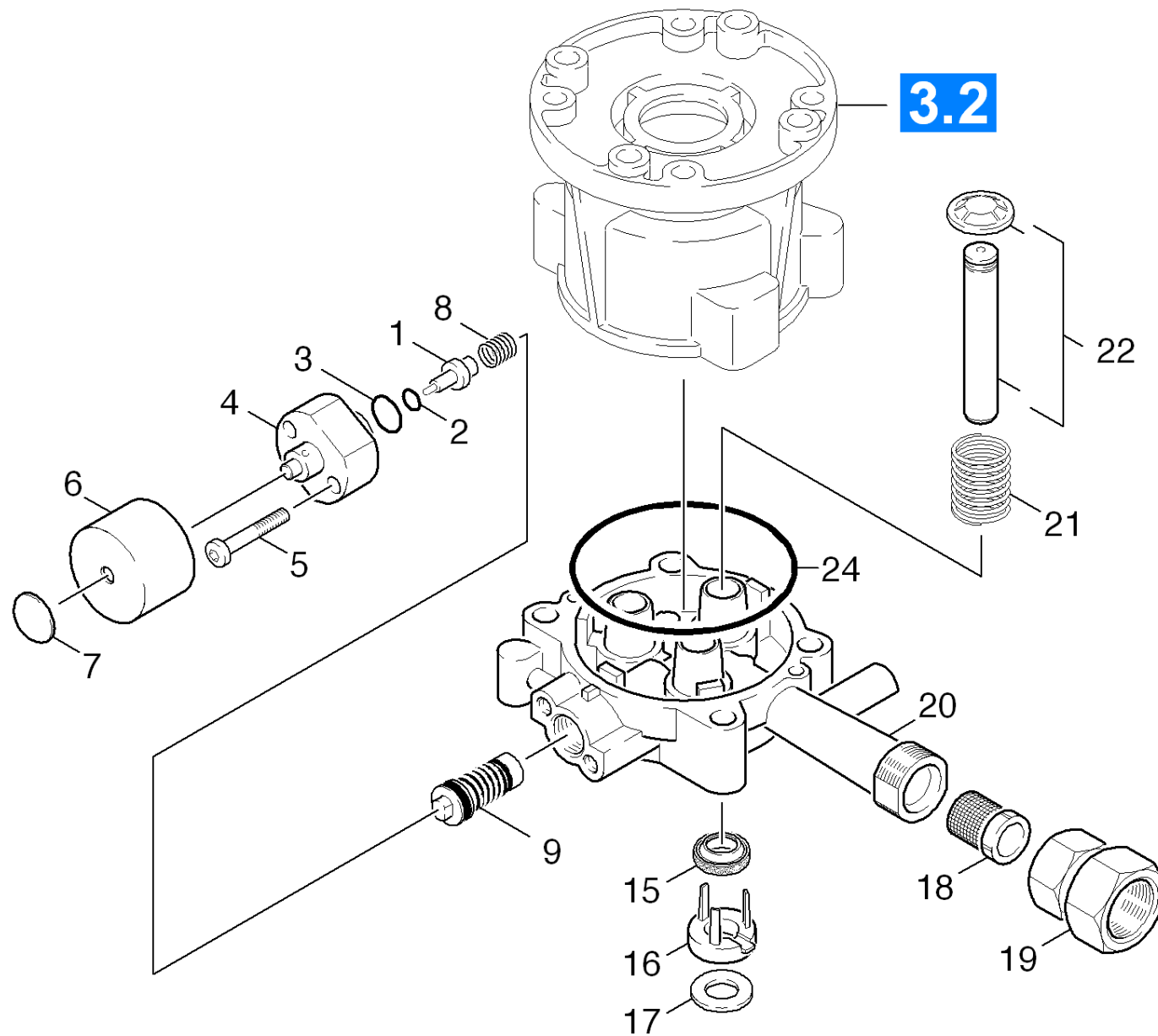

22 Piston (0.108-302.0)

ET/VT (spare/wear parts)	Pos	Material #	Name	Qty.	Unit	from ser.nr.	up to ser.nr.
	1	6.413-114.0	Therموالve 60°	1.000	ST	0000000000	0000000000
	2	7.362-507.0	O-Ring seal 8x2-NBR 90 DIN 3770	1.000	ST	0000000000	0000000000
	3	6.362-553.0	O-Ring seal 14,0 X 1,1	1.000	ST	0000000000	0000000000
	4	5.587-196.0	Valve housing	1.000	ST	0000000000	0000000000
	5	7.303-066.0	Screw M6x30 -St-R3R (In6Rd)	2.000	ST	0000000000	0000000000
	6	5.394-522.0	Protecting cap black	1.000	ST	0000000000	0000000000
	7	6.343-129.0	Lock washer	1.000	ST	0000000000	0000000000
	8	5.332-290.0	Helical spring	1.000	ST	0000000000	0000000000
	9	4.591-040.0	SPILL VALVE COMPLETE	1.000	ST	0000000000	0000000000
X-X	15	6.365-393.0	Oil sealing 12x20x4/6	3.000	ST	0000000000	0000000000
	16	5.115-903.0	Washer	3.000	ST	0000000000	0000000000
X-X	17	5.115-721.0	Washer	3.000	ST	0000000000	0000000000
X-X	18	6.414-252.0	Strainer	1.000	ST	0000000000	0000000000
	19	9.154-009.0	Coupling element 3/4"	1.000	ST	0000000000	0000000000
	20	5.060-838.0	Piston guidance	1.000	ST	0000000000	0000000000
X	21	5.332-391.0	Pressure spring	3.000	ST	0000000000	0000000000
	22	4.553-215.0	Piston complete	3.000	ST	0000000000	0000000000
	24	6.362-471.0	O-Ring seal 80,0 X 3,0 -NBR 70	1.000	ST	0000000000	0000000000

30 Motor (0.112-792.0)

Pos	Name	Qty.	Unit	from ser.nr.	up to ser.nr.
31	Motor	1.000	ST	0000000000	0000000000
32	Transmission	1.000	ST	0000000000	0000000000

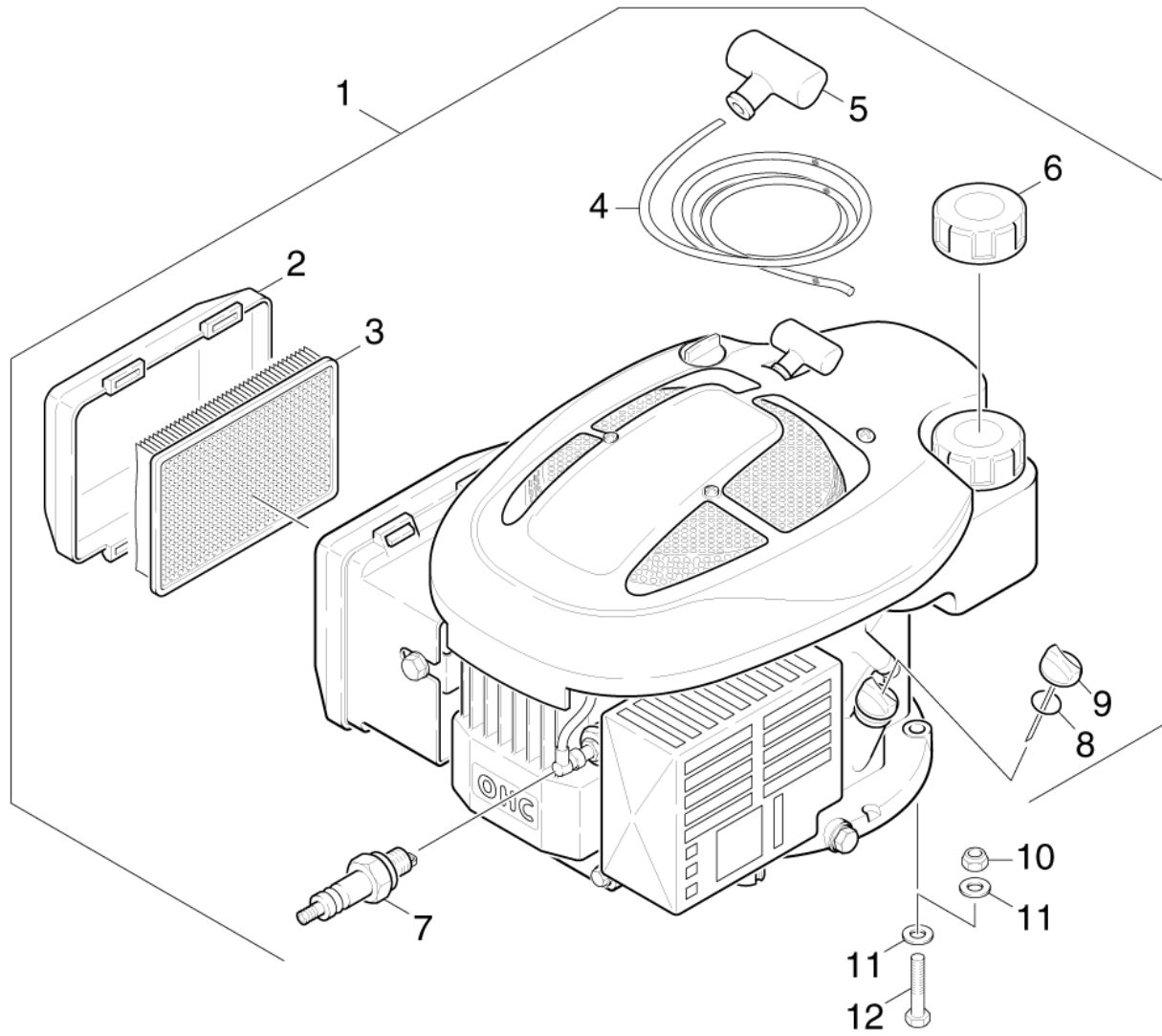

31 Motor (0.112-793.0)

ET/VT (spare/wear parts)	Pos	Material #	Name	Qty.	Unit	from ser.nr.	up to ser.nr.
	1	9.194-050.0	ENGINE, 6.0 HP TECUMSEH LV195	1.000	ST	0000000000	0000000000
	10	9.197-002.0	5/16-18 NE NYLON INSERT L/N ZC 5UM	4.000	ST	0000000000	0000000000
X-X	11	7.312-004.0	Washer 8 -200HV-A3E ISO 7090	8.000	ST	0000000000	0000000000
	12	6.965-007.0	5/16-24X1 GR 5 SHCS THRU HARDENED ZC	4.000	ST	0000000000	0000000000

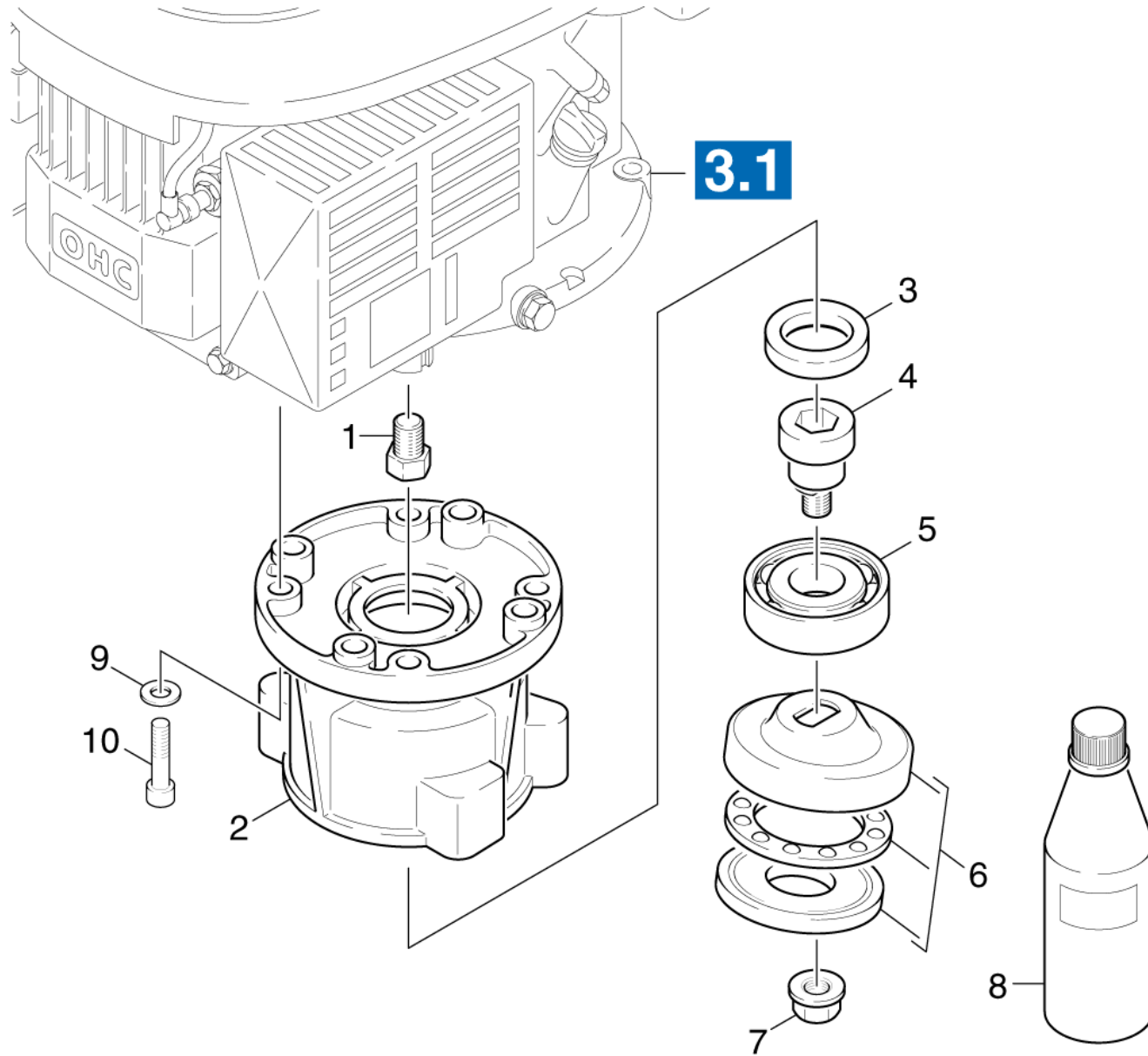

32 Transmission (0.112-794.0)

ET/VT (spare/wear parts)	Pos	Material #	Name	Qty.	Unit	from ser.nr.	up to ser.nr.
	1	9.152-252.0	DRIVE BOLT 7/16" -20UNF-2B	1.000	ST	0000000000	0000000000
	2	5.093-199.0	Housing vertical	1.000	ST	0000000000	0000000000
	3	7.367-018.0	Radial shaft seal ring A26x37x7 -NBR DI	1.000	ST	0000000000	0000000000
	4	9.039-072.0	Coupler	1.000	ST	0000000000	0000000000
	5	7.401-155.0	Ball bearing 6304-WAELZLAGERST DIN 625	1.000	ST	0000000000	0000000000
	6	6.401-256.0	Wobble plate	1.000	ST	0000000000	0000000000
	7	9.086-303.0	Nut	1.000	ST	0000000000	0000000000
X	8	6.288-050.0	Engine oil 1L	1.000	ST	0000000000	0000000000
	9	5.115-656.0	Washer	4.000	ST	0000000000	0000000000
	10		Stockpiling discontinued	4.000	ST	0000000000	0000000000

40 Accessories (0.148-498.0)

Pos	Name	Qty.	Unit	from ser.nr.	up to ser.nr.
41	Hand trigger gun	1.000	ST	0000000000	0000000000
42	Hand trigger gun	1.000	ST	0000000000	0000000000
43	Jet pipe	1.000	ST	0000000000	0000000000

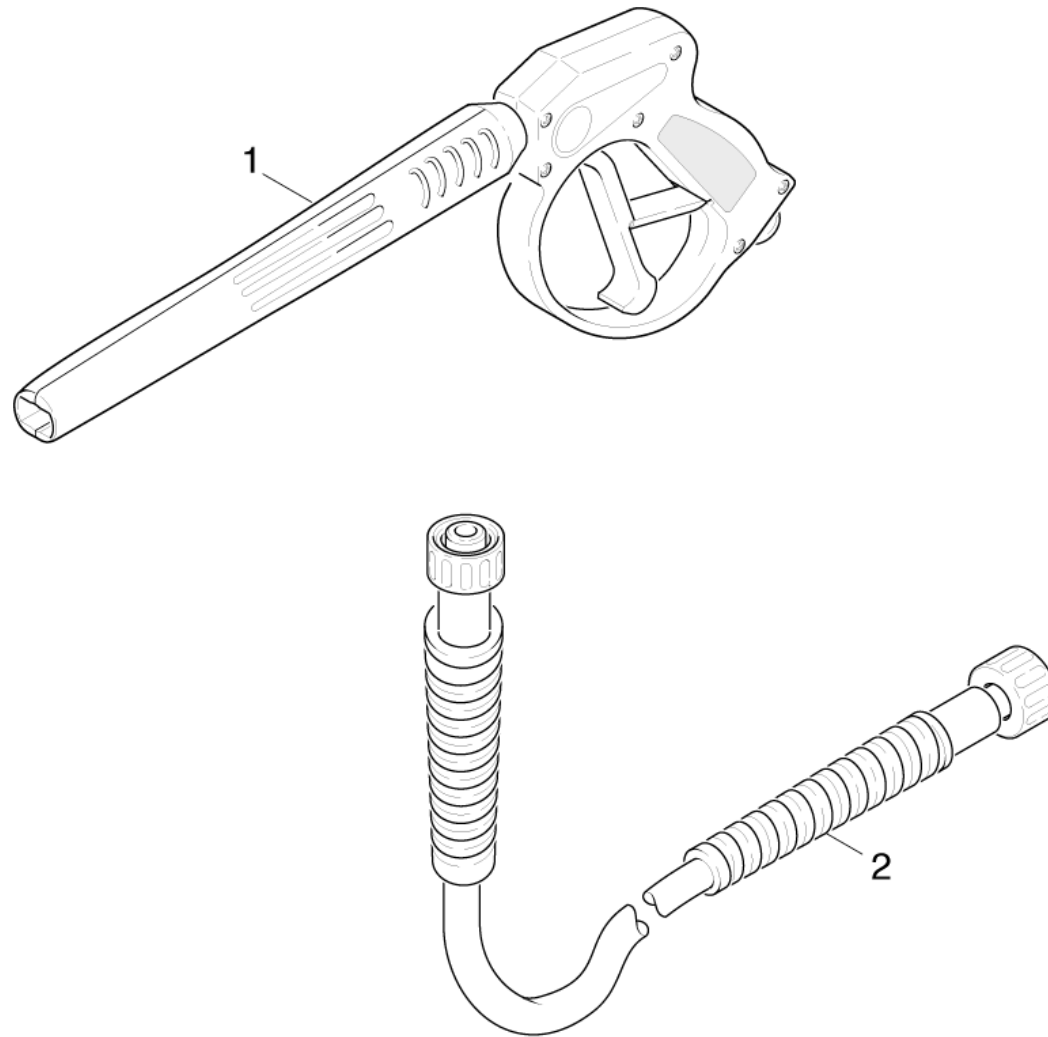

41 Hand trigger gun (0.148-499.0)

Pos	Material #	Name	Qty.	Unit	from ser.nr.	up to ser.nr.
1		Stockpiling discontinued	1.000	ST	0000000000	0000000000
2	9.162-321.0	HP HOSE DN6/25'/3000/KA/BLK/PLSTC	1.000	ST	0000000000	0000000000

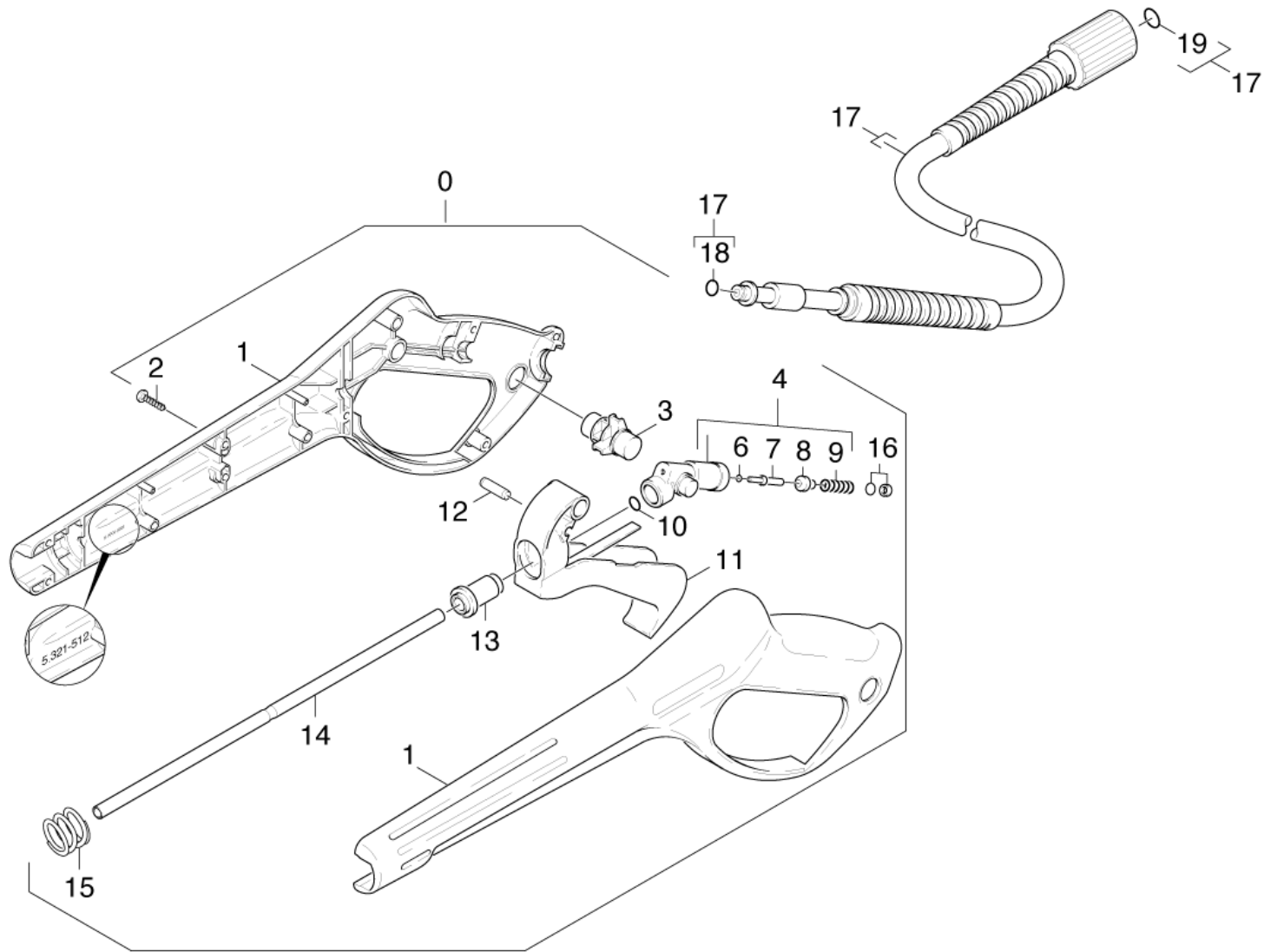

42 Hand trigger gun (0.148-607.0)

ET/VT (spare/wear parts)	Pos	Material #	Name	Qty.	Unit	from ser.nr.	up to ser.nr.
	0	4.775-264.0	Pistol only for replacement 96	1.000	ST	0000000000	0000000000
	1	5.321-512.0	Handhold few	1.000	ST	0000000000	0000000000
	2	6.303-122.0	M4 .2X13 DIN 7981 TORX T15 PAN HD HI/LO	9.000	ST	0000000000	0000000000
	3	5.481-189.0	Lever locking part	1.000	ST	0000000000	0000000000
	4	4.427-178.0	Manifold complete	1.000	ST	0000000000	0000000000
	6	7.362-502.0	O-Ring seal 2,8x1,6-NBR 70 DIN 3770	1.000	ST	0000000000	0000000000
	7	5.107-147.0	Bar	1.000	ST	0000000000	0000000000
	8	5.582-058.0	Valve disc	1.000	ST	0000000000	0000000000
	9	5.332-157.0	Helical spring	1.000	ST	0000000000	0000000000
	10	6.362-479.0	O-Ring seal 7,59X 2,62	1.000	ST	0000000000	0000000000
	11	4.481-105.0	Lever complete	1.000	ST	0000000000	0000000000
	12	5.314-082.0	Pin -BONEZZI 12.022.706	1.000	ST	0000000000	0000000000
	13	5.110-539.0	Sleeve	1.000	ST	0000000000	0000000000
	14	5.028-905.0	Tube pistol	1.000	ST	0000000000	0000000000
	15	5.332-349.0	Pressure spring	1.000	ST	0000000000	0000000000
	16	6.363-198.0	O-Ring seal 6x2 90 shore PUR	1.000	ST	0000000000	0000000000
	17	4.440-607.0	High pressure hose 9m/16MPa, Kaer., 60G	1.000	ST	0000000000	0000000000
X-X	18	6.363-115.0	O-Ring seal complete 1ST.-R.	1.000	ST	0000000000	0000000000
X-X	19	2.880-154.0	O-Ring kit	1.000	ST	0000000000	0000000000

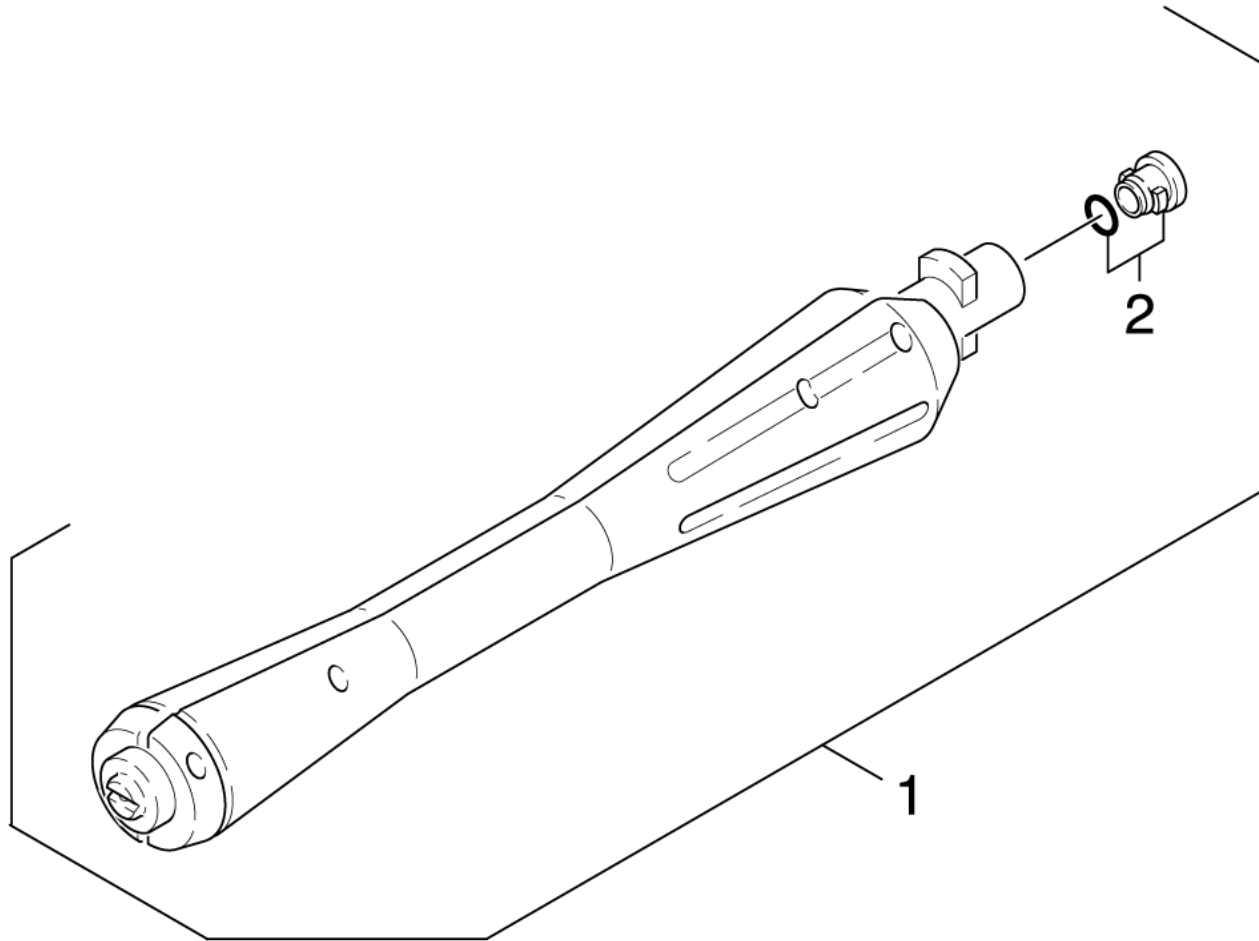

43 Jet pipe (0.148-500.0)

ET/VT (spare/wear parts)	Pos	Material #	Name	Qty.	Unit	from ser.nr.	up to ser.nr.
	1	4.760-382.0	Jet pipe VP0295	1.000	ST	0000000000	0000000000
X	2	2.640-729.0	O-Ring seal set	1.000	ST	0000000000	0000000000