

FEATURES

- Designed and engineered exclusively for pressure washers.
- Five year limited warranty.
- Forged brass manifold with an exclusive lifetime warranty.
- Die-cast, anodized aluminum oil-bath crankcase.
- Aluminum two piece connecting rods with lubrication channels for maximum life.
- Heavy-duty crankshaft bearings.
- Solid ceramic plungers with mirror finish and corrosion resistance.
- Stainless steel inlet and discharge valve assemblies.
- Forged valve caps with recessed O-rings.
- Dacromet® coated manifold bolts for extra corrosion resistance.
- Precision oil dipstick for proper ventilation of crankcase.
- Parker® low and high pressure seals.



SPECIFICATIONS

PUMP MODEL	KD-3025	KD-3030	KD-4020
Maximum Volume GPM/LPM	3 / 11.3	3 / 11.3	4.0 / 15
Max. Discharge Pressure PSI/BAR	2500 / 175	3000 / 207	2000 / 140
Maximum Pump Speed RPM	1180	1650	1550
Maximum Inlet Pressure PSI/BAR	125 / 8.6		
Maximum Inlet Vacuum	2.6 in. HG / 66 mm HG		
Bore	18 mm	15 mm	18 mm
Stroke	13.6 mm		
Crankcase Oil Capacity	14 oz. / .41 liter		
Maximum Fluid Temperature	165° F / 74°C		165° F / 74°C
Inlet Port Thread	1/2-14 BSPP-F		
Discharge Port Thread	3/8-19 BSPP-F		
Shaft Diameter	24 mm		
Weight	16 lbs / 7.25 kg		
Dimensions (LxWxH) in/mm	8.5 x 8.4 x 5.0 / .22 x .21 x .13		
Part Number	9.803-417.0	9.804-006.0	9.804.019.0

KÄRCHER KD Series Pump

9.803-824.0 KD 3025
 9.803-825.0 KD 3030
 9.803-827.0 KD 4020

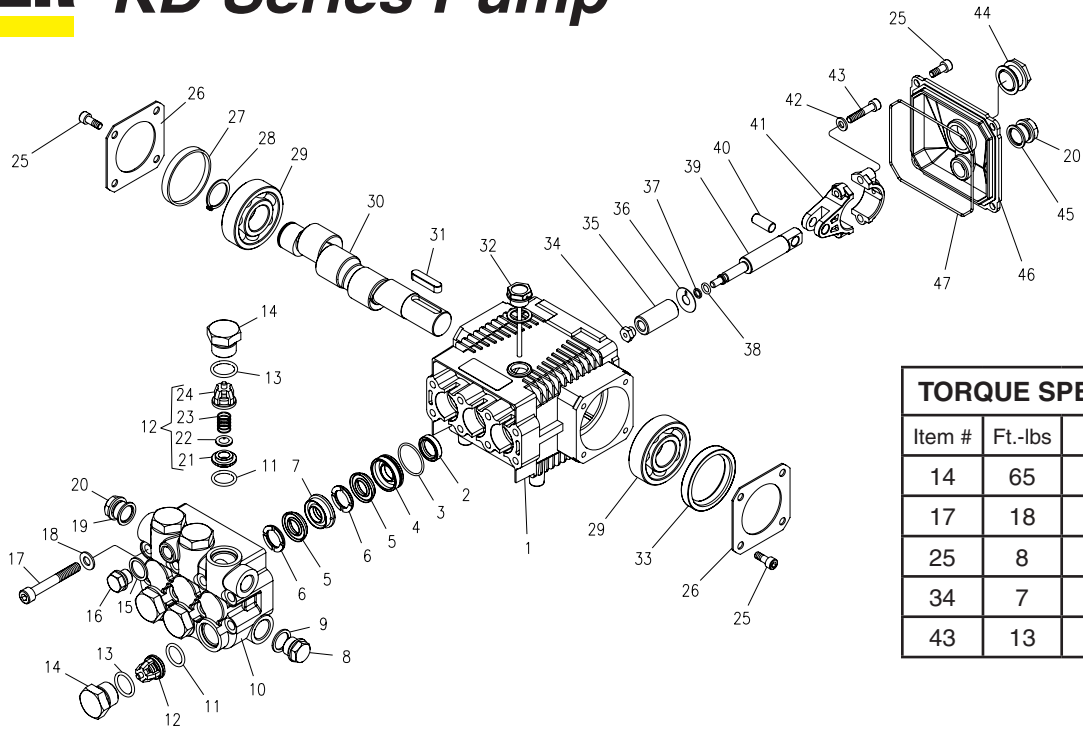

TORQUE SPECS		
Item #	Ft.-lbs	Nm
14	65	8
17	18	25
25	8	11
34	7	9
43	13	17

PARTS LIST

ITEM	PART NO.	DESCRIPTION	QTY	ITEM	PART NO.	DESCRIPTION	QTY	ITEM	PART NO.	DESCRIPTION	QTY
1	9.803-938.0	Crankcase	1	11*	9.803-947.0	O-Ring Ø1.78 x 15.54	6	33	9.803-958.0	Crankshaft Seal	1
2*	See Kits Below	Plunger Oil Seal	3	12*	See Kits Below	Valve Assembly	6	34*	9.803-959.0	Plunger Nut	3
3*	9.803-939.0	O-Ring Ø1.78 x 28.30	3	13*	9.803-948.0	O-Ring Ø2.62 x 18.77	6	35*	9.803-960.0	Plunger, 15mm (3030)	3
4*	9.803-940.0	Pressure Ring 15mm (3030)	3	14	9.803-949.0	Valve Plug	6	9.803-961.0	Plunger, 18mm (4020, 3025)	3	
	9.803-941.0	Pressure Ring 18mm (4020, 3025)	3	15	9.803-950.0	Copper Washer 1/4	1	36*	9.803-962.0	Copper Spacer	3
5*	See Kits Below	"V" Seal, 15mm (3030)	6	16	9.803-951.0	Brass Plug G1/4	1	37*	9.803-963.0	O-Ring Ø1.78 x 5.28	3
	See Kits Below	"V" Seal, 18mm (4020, 3025)	6	17	9.803-952.0	Manifold Stud Bolt	8	38*	9.803-156.0	Teflon Ring	3
6*	9.803-942.0	Support Ring 15mm (3030)	6	18	9.802-884.0	Washer	8	39*	9.803-964.0	Plunger Rod	3
	9.803-943.0	Support Ring 18mm (4020, 3025)	6	19	9.803-198.0	Copper Washer 3/8	1	40	9.803-965.0	Connecting Rod Pin	3
7*	9.803-944.0	Intermed. Ring 15mm (3030)	3	20	9.802-925.0	Brass Plug 3/8	2	41	9.803-966.0	Connecting Rod	3
	9.803-945.0	Intermed. Ring 18mm (4020, 3025)	3	25	9.802-939.0	Screw	12	42	9.803-218.0	Spring Washer	6
8	9.802-926.0	Brass Plug 1/2"	1	26	9.803-953.0	Bearing Cover	2	43	9.803-967.0	Connecting Rod Screw	6
9	9.803-199.0	Copper Washer 1/2"	1	27	9.803-954.0	Bearing Seal	1	44	9.803-202.0	Sight Glass	1
10	9.803-946.0	Manifold Housing	1	28	9.802-914.0	Snap Ring	1	45	9.803-197.0	Gasket	1
				29	9.803-955.0	Ball Bearing	2	46	9.803-968.0	Crankcase Cover	1
				30	9.803-956.0	Crankshaft	1	47	9.803-969.0	O-Ring Ø2.62 x 107.62	1
				31	9.803-167.0	Crankshaft Key	1				
				32	9.803-957.0	Oil Dipstick	1				

* Available in kit (See below)

REPAIR KITS

REPAIR KIT NUMBER	9.803-930.0	9.803-931.0	9.803-932.0	9.803-933.0	9.803-934.0	9.803-935.0	9.803-936.0	9.803-937.0
KIT DESCRIPTION	*Plunger Seal 15mm KD-3030	Plunger Seal 18mm KD-3025 KD-4020	**Complete Seal Packing KD-3030	Complete Seal Packing KD-3025 KD-4020	Plunger 15mm KD-3030	Plunger 18mm KD-3025 KD-4020	Complete Valve	Plunger Oil Seals
ITEM NO.'S INCLUDED	3, 5, 6	3, 5, 6	2, 3, 4, 5, 6, 7	2, 3, 4, 5, 6, 7,	34, 35, 36, 37, 38	34, 35, 36, 37, 38	11, 12, 13	2
NO. OF CYLINDERS KIT WILL SERVICE	3	3	1	1	1	1	6	3