

FEATURES

- Five year limited warranty.
- Forged brass manifold with an exclusive lifetime warranty.
- Large capacity, die-cast, anodized aluminum oil-bath crankcase.
- Over-sized connecting rods and crankshaft for maximum life.
- Heavy-duty tapered roller bearings.
- Solid ceramic plungers with mirror finish and corrosion resistance.
- Parker "U" seals for premium performance.
- Stainless steel inlet and discharge valve assemblies.
- Machined stainless steel valve caps with recessed O-rings to withstand high pressures.
- Dacromet® coated manifold bolts for superior corrosion resistance.

**SPECIFICATIONS**

PUMP MODEL	KH 5050
Maximum Volume (GPM)	5
Max. Discharge Pressure (PSI)	5000
Maximum Pump Speed	1650
Maximum Inlet Pressure	125 psi
Maximum Inlet Vacuum	9 ft. water (7.9 in. Hg)
Bore	18mm
Stroke	17mm
Crankcase Oil Capacity	40 oz.
Maximum Fluid Temperature	165° F
Inlet Port Thread	1/2" BSP
Discharge Port Thread	3/8" BSP
Shaft Diameter x Shaft Length	25mm x 55mm
Weight	39 lbs
Dimensions (L x W x H)	12.85 x 10.23 x 6.45

KH 5050 Pump

9.804-491.0 KH5050-Right
8.749-520.0 KH5050-Left

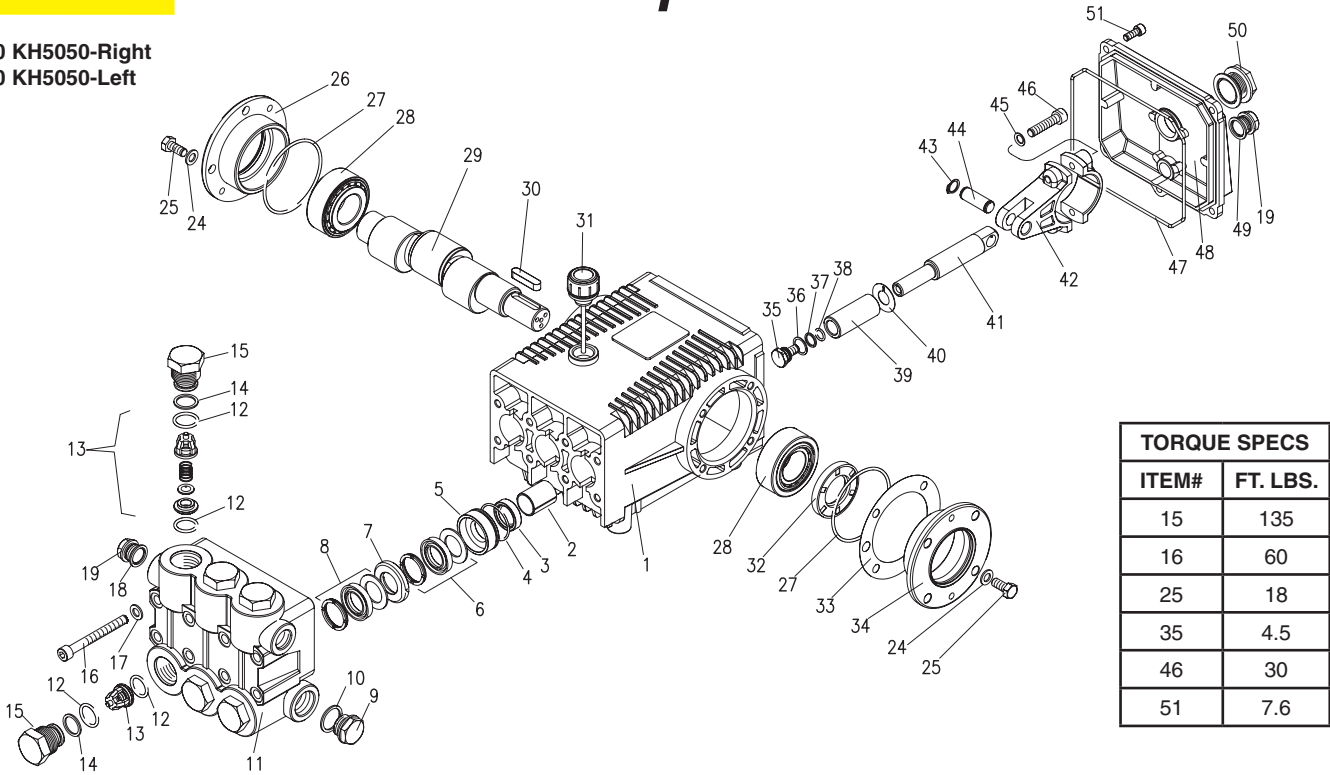

PARTS LIST

ITEM	PART NO.	DESCRIPTION	QTY	ITEM	PART NO.	DESCRIPTION	QTY	ITEM	PART NO.	DESCRIPTION	QTY
1	9.803-163.0	Crankcase	1	17	9.802-890.0	Lock Washer	8	37*	9.803-188.0	O-Ring Ø1.78x7.66	3
2	9.803-195.0	Plunger Guide	3	18	9.803-198.0	Copper Washer 3/8	1	38*	9.803-155.0	Teflon Ring	3
3*	See Kit Below	Plunger Oil Seal	3	19	9.802-925.0	Brass Plug 3/8	2	39*	See Kit Below	Plunger 18mm	3
4*	See Kits Below	O-Ring Ø1.78 x 37.82	3	24	9.802-884.0	Washer	8	40*	9.802-888.0	Copper Spacer	3
5*	See Kits Below	Pressure Ring 18mm	3	25	9.802-944.0	Hex Screw	8	41	9.803-294.0	Plunger Rod	3
6*	See Kit Below	U Seal, Dia. 18 x 28mm	3	26	9.804-501.0	Closed Bearing Housing	1	42	9.803-157.0	Connecting Rod	3
7*	See Kits Below	Support Ring 18mm	3	27	9.803-186.0	O-Ring Ø2.62 x 71.12	2	43	9.802-912.0	Snap Ring	6
8*	See Kits Below	U Seal, Dia 18 x 28mm	3	28	9.804-502.0	Roller Bearing	2	44	9.802-915.0	Connecting Rod Pin	3
9	9.802-926.0	Brass Plug, 1/2	1	29	9.803-289.0	Crankshaft	1	45	9.802-889.0	Spring Washer	6
10	9.803-199.0	Copper Washer 1/2	1	30	9.803-293.0	Crankshaft Key	1	46	9.802-937.0	Connecting Rod Screw	6
11	8.717-516.0	Manifold Housing	1	31	9.802-923.0	Oil Dip Stick	1	47	70-060185	O-Ring Ø2.62 x 152.07	1
12*	9.804-498.0	O-Ring Ø2.62 x 17.13	6	32	9.803-139.0	Crankshaft Seal	1	48	9.803-166.0	Crankcase Cover	1
13*	See Kit Below	Valve Assembly	6	33	9.803-177.0	Shim	2	49	9.803-197.0	Gasket, G3/8	1
14*	9.804-500.0	Teflon Ring	6	34	9.804-503.0	Bearing Housing	1	50	9.803-202.0	Sight Glass G3/4	1
15	9.803-292.0	Valve Plug	6	35*	9.802-936.0	Plunger Bolt	3	51	9.802-939.0	Cover Screw	5
16	9.802-942.0	Manifold Stud Bolt	8	36*	9.802-885.0	Copper Spacer	3				

* Available in kit (See below)

REPAIR KITS

KIT NUMBERS	9.804-492.0	9.804-493.0	9.802-629.0	9.802-604.0	9.802-606.0
KIT DESCRIPTION	Plunger Seal 18 mm	Seal Packing 18 mm	Plunger 18 mm	Complete Valve	Plunger Oil Seals
ITEMS NUMBERS INCLUDED	4, 6, 8	4, 5, 6, 7, 8	35, 36, 37, 38, 39, 40	12, 13, 14	3
NUMBER OF CYLINDERS KIT WILL SERVICE	3	1	1	6	3